

MOBILE COMMUNICATION AND INTERNET TECHNOLOGIES

E-Commerce/M-Commerce
Infrastructure – The Internet

<http://web.uettaxila.edu.pk/CMS/2017/SPR2017/teMCITms/>

E-COMMERCE & M-COMMERCE INFRASTRUCTURE

Most of commerce (and e-Commerce) is exchange of information, not goods

The most efficient way to move information (cost per bit) to a large number of destinations is the Internet

Allows point-to-point communication with arbitrary people and companies

The Internet is getting bigger fast

INTERNET HOST COUNT 1991-2003

“Host” computer that can be reached by a URL

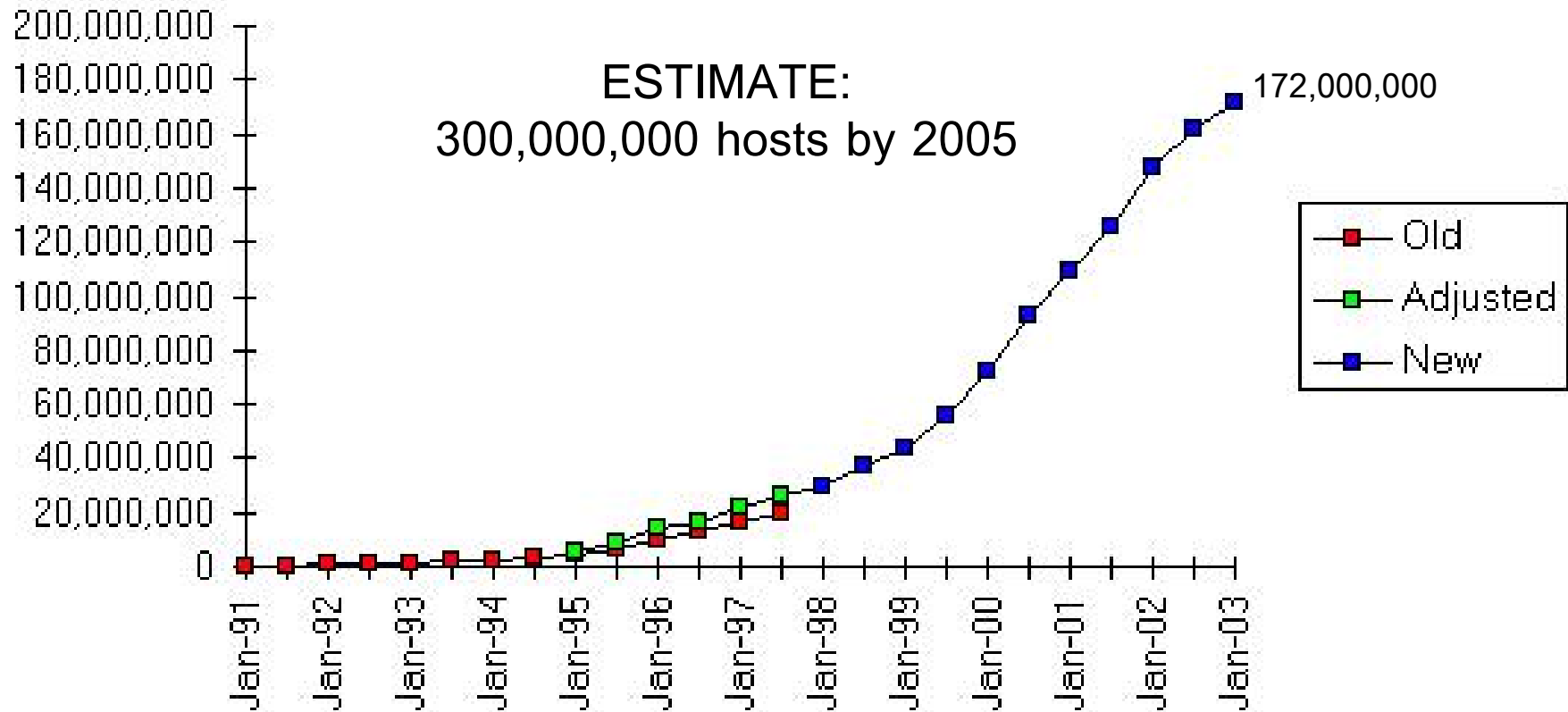

Source: Internet Software Consortium (www.isc.org)

Internet Domain Survey Host Count

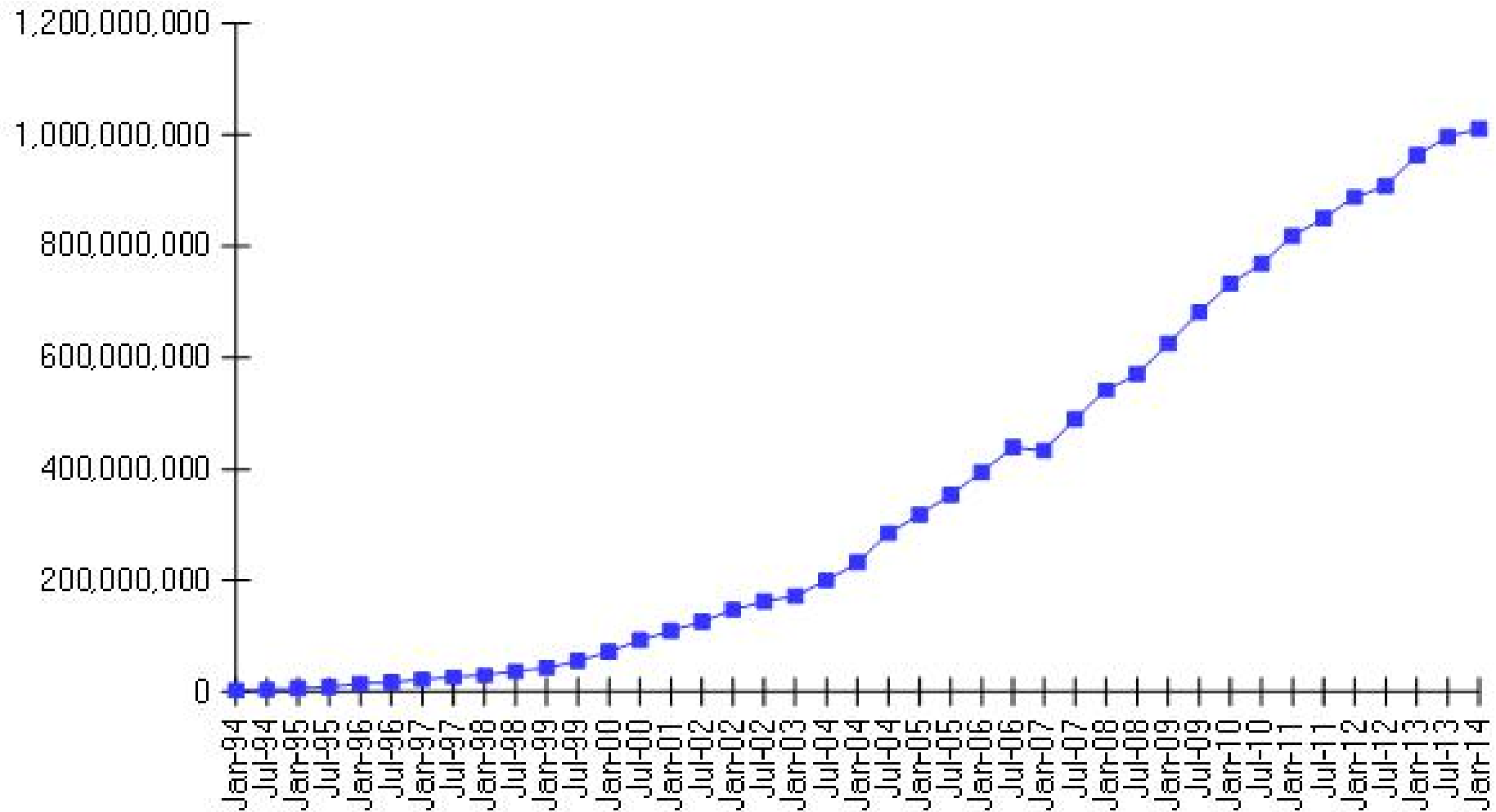

Source: Internet Systems Consortium (www.isc.org)

INTERNET LEVERAGE BY COUNTRY

LEVERAGE = % OF INTERNET USERS ÷ % OF WORLD POPULATION

WORLD TOTAL USERS (AUG. 2003): 700,000,000

Rank	Country	~Users	% of Users	% of World	Leverage
1	U.S.	166M	25.0	4.52	5.55
2	Japan	56M	8.4	2.05	4.20
3	China	46M	7.0	20.97	0.33
4	U.K.	35M	5.3	0.97	5.46
5	Germany	32M	4.8	1.34	3.58
6	S. Korea	26M	3.9	0.78	5.00
7	Italy	20M	3.0	0.93	3.23
8	Russia	18M	2.7	2.34	1.15
9	France	17M	2.6	0.97	2.68
10	Canada	17M	2.6	0.51	5.10
11	Brazil	14M	2.1	2.84	0.74
12	Australia	11M	1.7	0.32	5.31
13	Netherlands	10M	1.5	0.26	5.77

BANDWIDTH REVIEW

Bit (b) = a unit of information, 0 or 1

10 bits can represent 1024 different messages

20 bits represent > 1 million

30 bits > 1 billion messages

The bandwidth of a communication channel = number of bits per second it transmits

All channels have limited bandwidth

One byte (B) = 8 bits (an octet)

Transmitting 1 MB at 56K bps takes 143 sec.

1 GB = gigabyte takes 40 hours

at 7Mbps 19 minutes; at 1 Gbps takes 8 seconds)

Latency = delay from first bit transmitted to first received

BANDWIDTH CHART

**O
P
T
I
C
A
L**

**C
O
P
P
E
R**

Bandwidth	Technology	Application
1 Terabit	DWDM Fiber	All U.S. phone conversations
10 Gbps	OC-192	Metropolitan Area Ethernet (MAE)
2.5 Gbps	OC-48	Long-haul Internet backbone
1 Gbps	Gigabit Ethernet	Gigabit Ethernet
622 Mbps	OC-12, Full-motion HDTV	Full-motion HDTV uncompressed
500 Mbps	USB 2.0, UWB limit	USB 2.0, UWB limit
155 Mbps	OC-3, FDDI	Internet backbone
1 Gbps	Gigabit Ethernet	Gigabit Ethernet
100 Mbps	Fast Ethernet	Fast Ethernet
50 Mbps	802.11a, Wi-Fi	Virtual reality
44.7 Mbps	T3	Medical imaging
11 Mbps	802.11b, Wireless LAN	802.11b, Wireless LAN
6.1 Mbps	ADSL download	Video conferencing, multimedia
2 Mbps	802.11, Bluetooth limit	Old wireless LAN
1.44 Mbps	T1	Streaming Video
128 Kbps	ISDN	ISDN
64 Kbps	Telephone PCM	Voice traffic
56 Kbps	Modem	Web browsing (slow)
30 bps	Human speech	Human speech

LINK

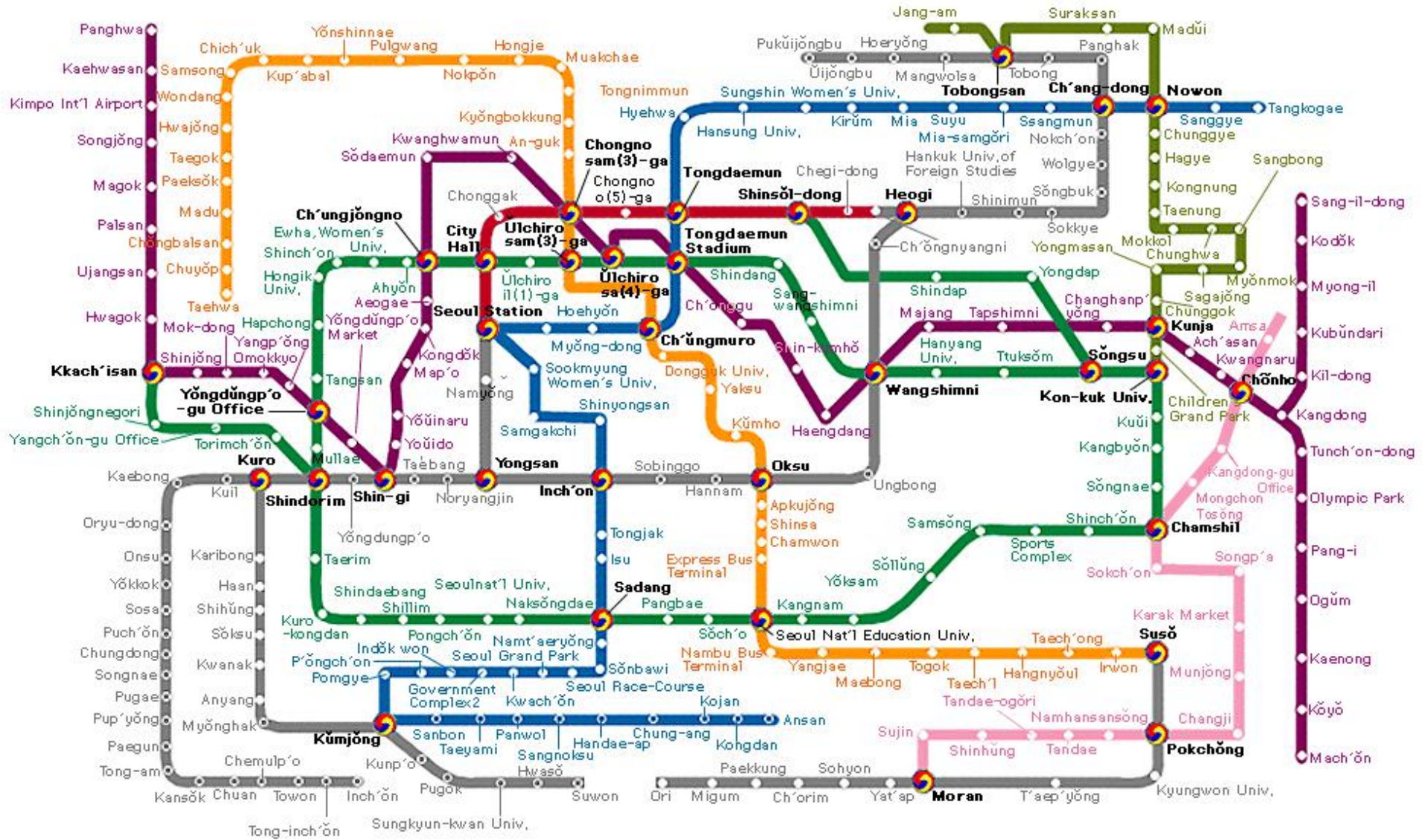

STRUCTURE OF THE INTERNET

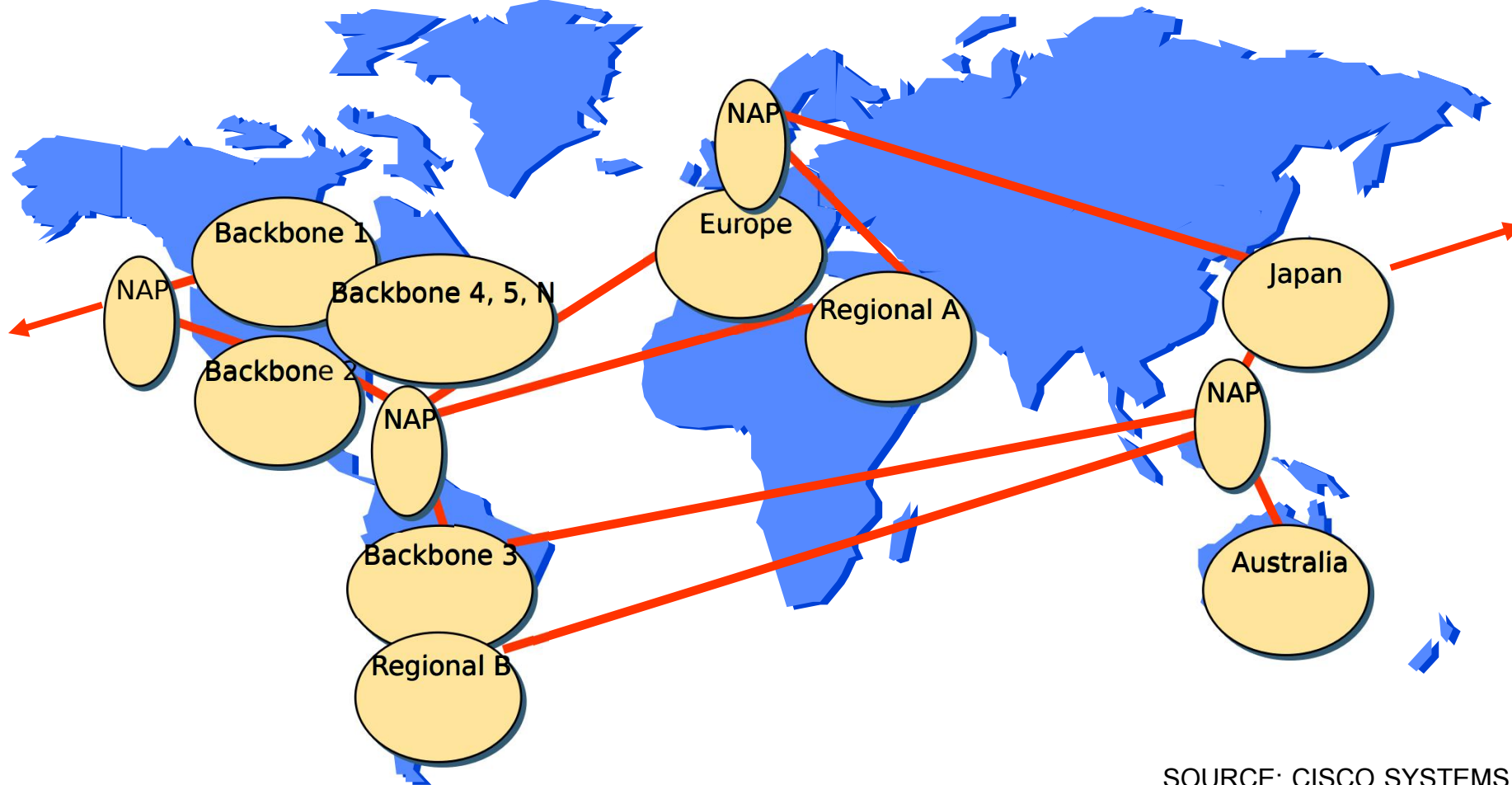

Link of
IXPs

SOURCE: CISCO SYSTEMS

EUROPEAN INTERCONNECTION STRUCTURE

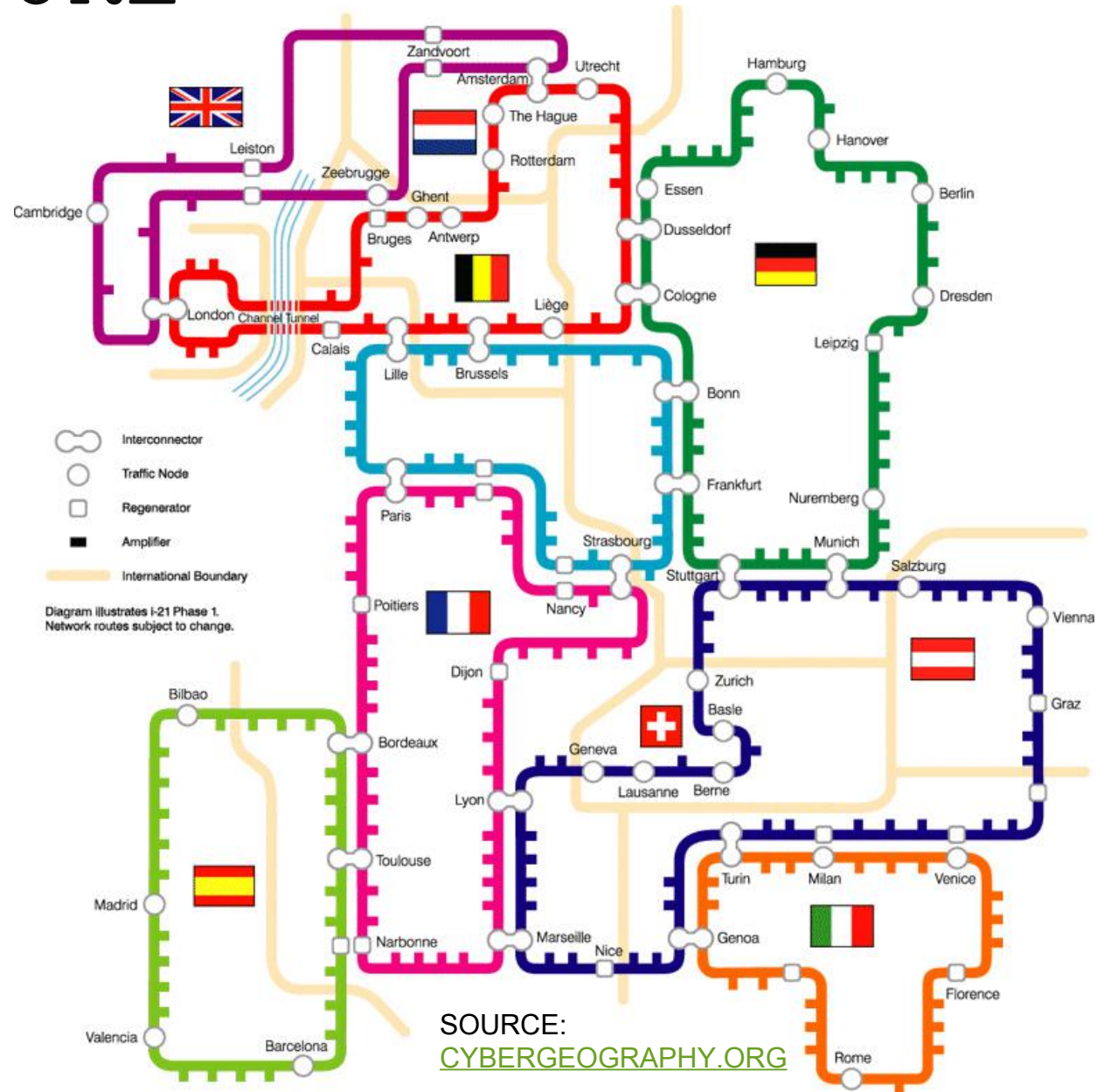

INTERNET NETWORK ARCHITECTURE

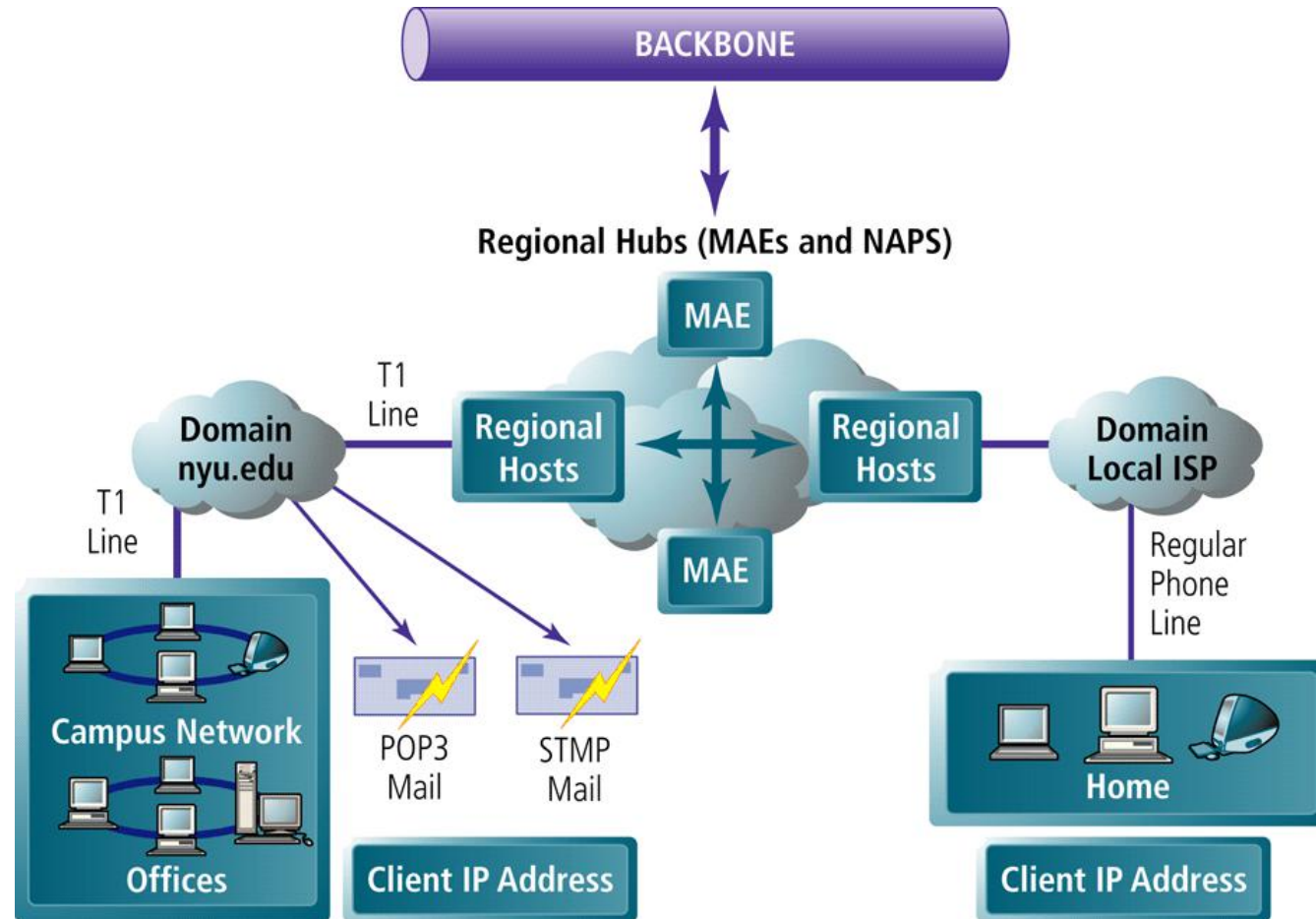

CONNECTING TO THE INTERNET

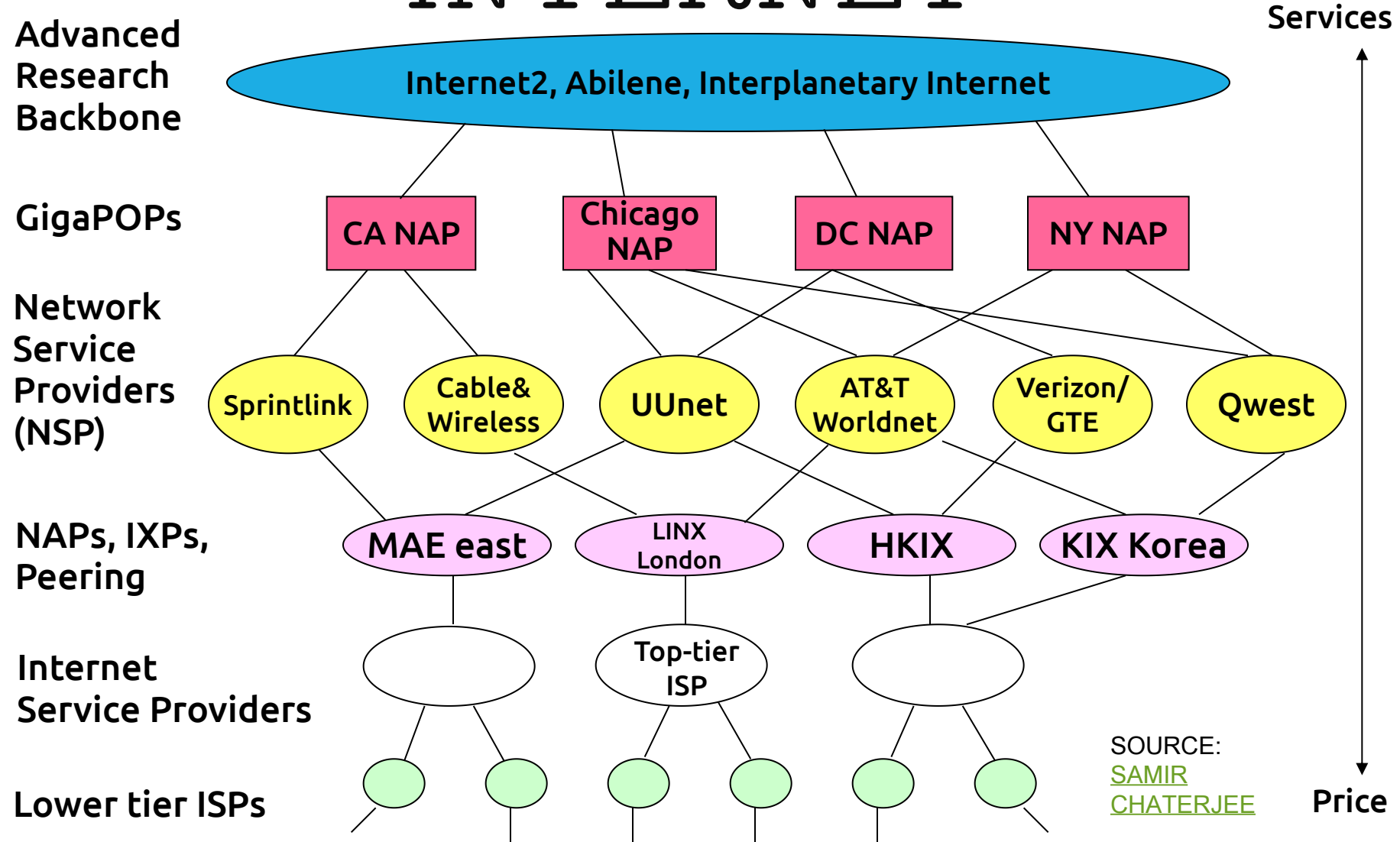

The Abilene Network

completed connections:
 221 participants
 58 connectors + 3 NGIXs + STAR TAP
 50 connections to 30 peer networks

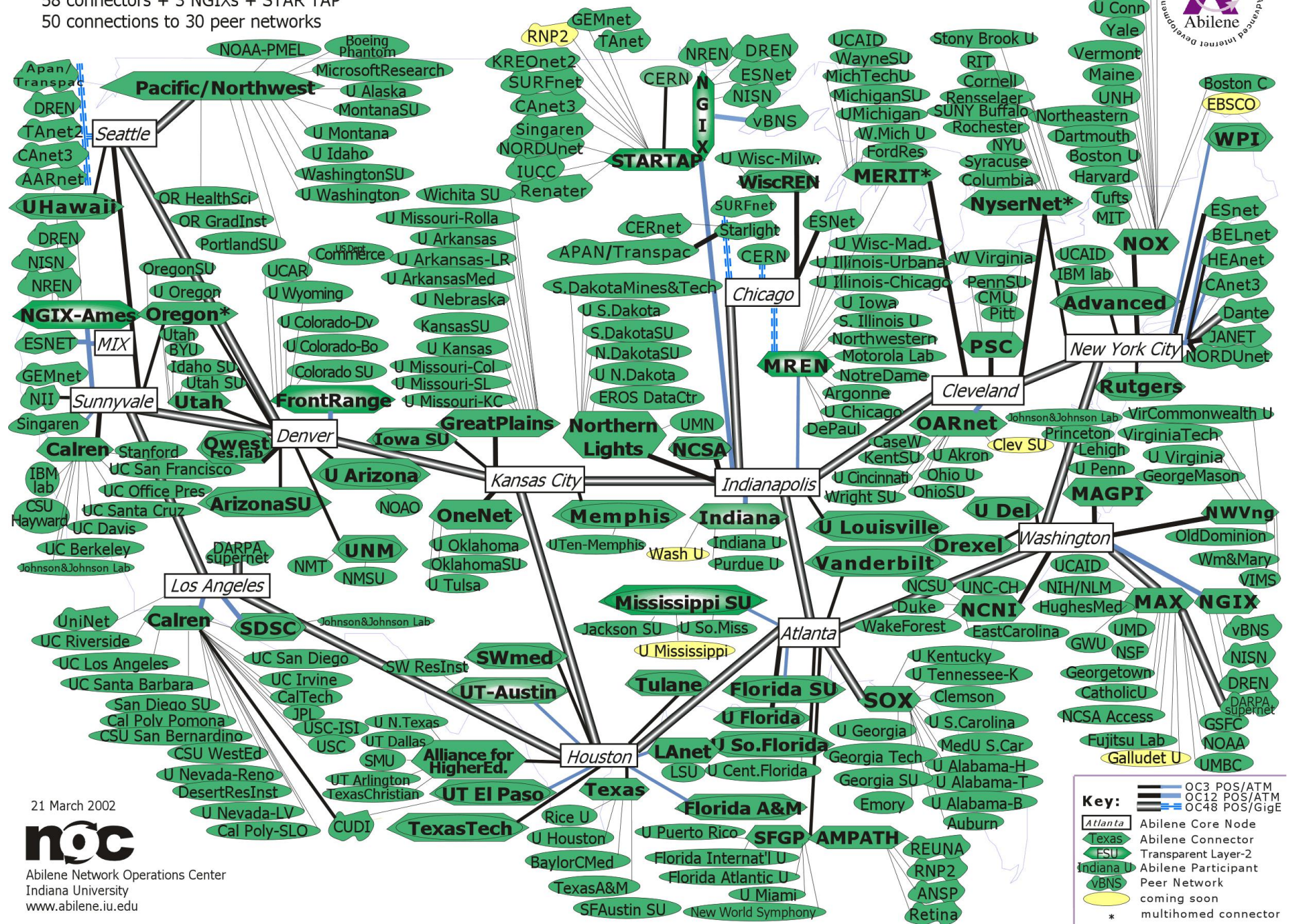

21 March 2002
 Abilene Network Operations Center
 Indiana University
 www.abilene.iu.edu

Key:

- OC3 POS/ATM
- OC12 POS/ATM
- OC48 POS/GigE
- Atlanta Abilene Core Node
- Texas Abilene Connector
- ESU Transparent Layer-2
- Indiana U Abilene Participant
- VBNS Peer Network
- coming soon
- * multihomed connector

PAKISTAN INTERNET EXCHANGE (PIE)

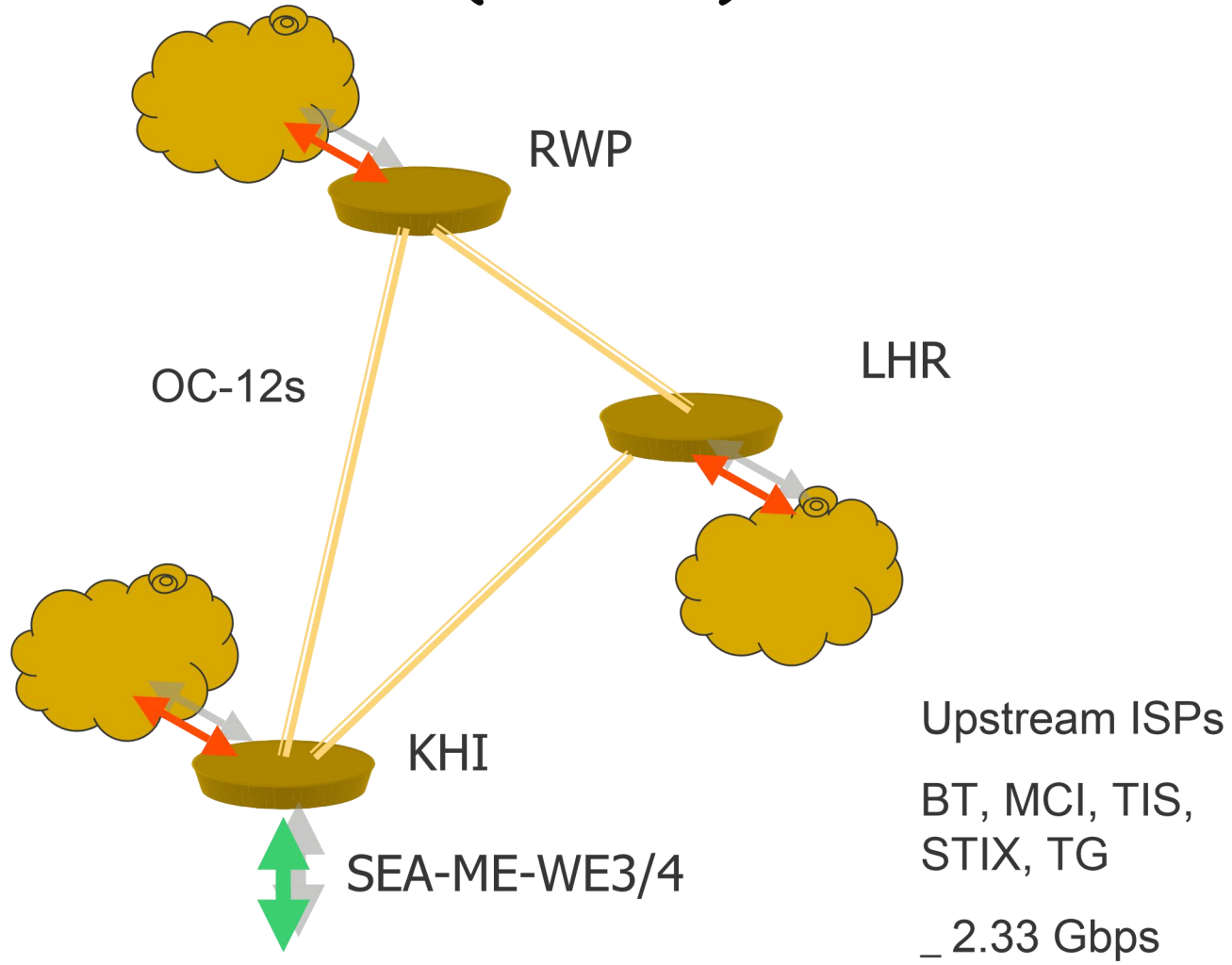

Source: Tariq M. Jadoon & M. Amir Mehmood (PTCL)

PIE - LOGICAL DIAGRAM

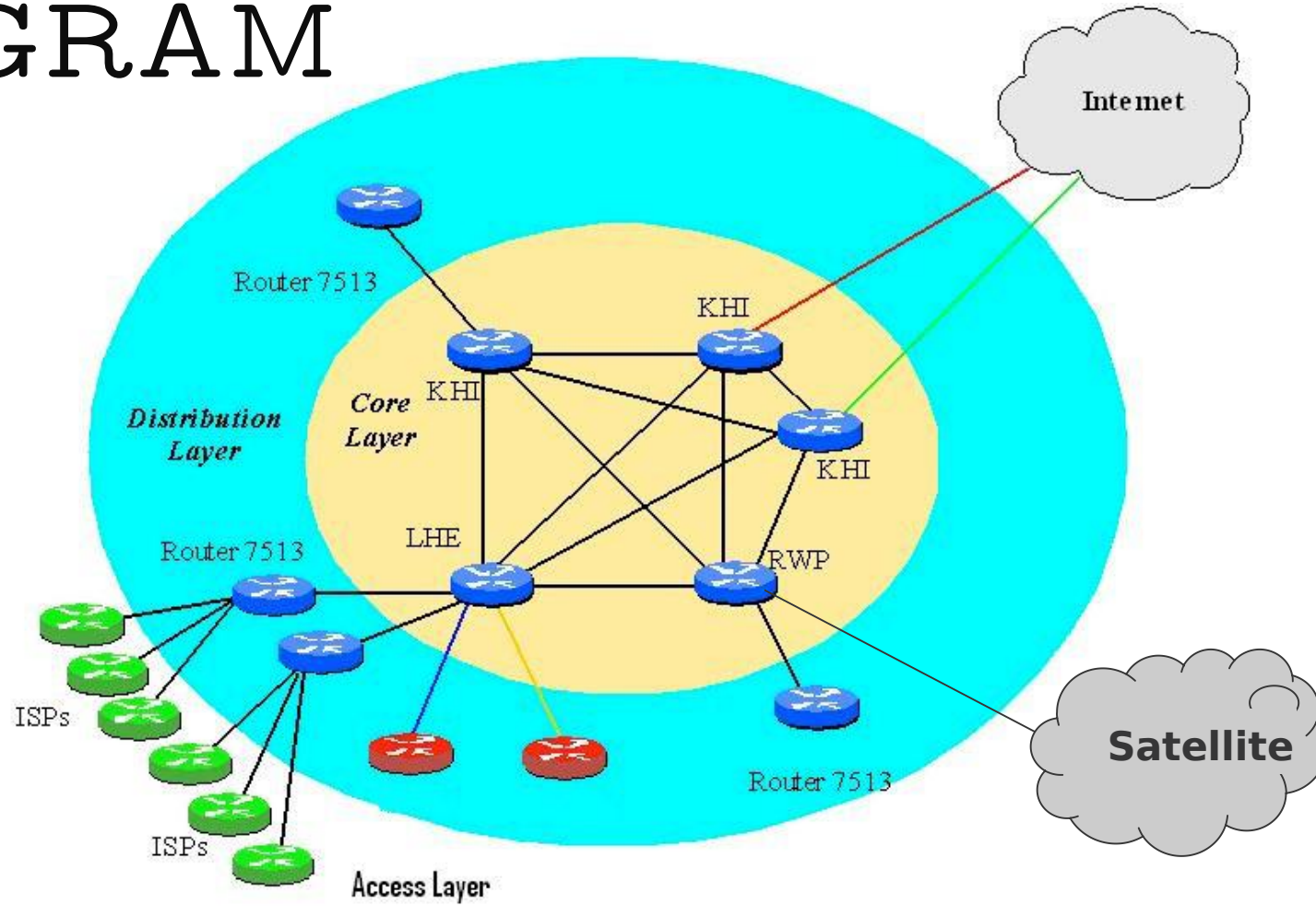

FIBER OPTICS

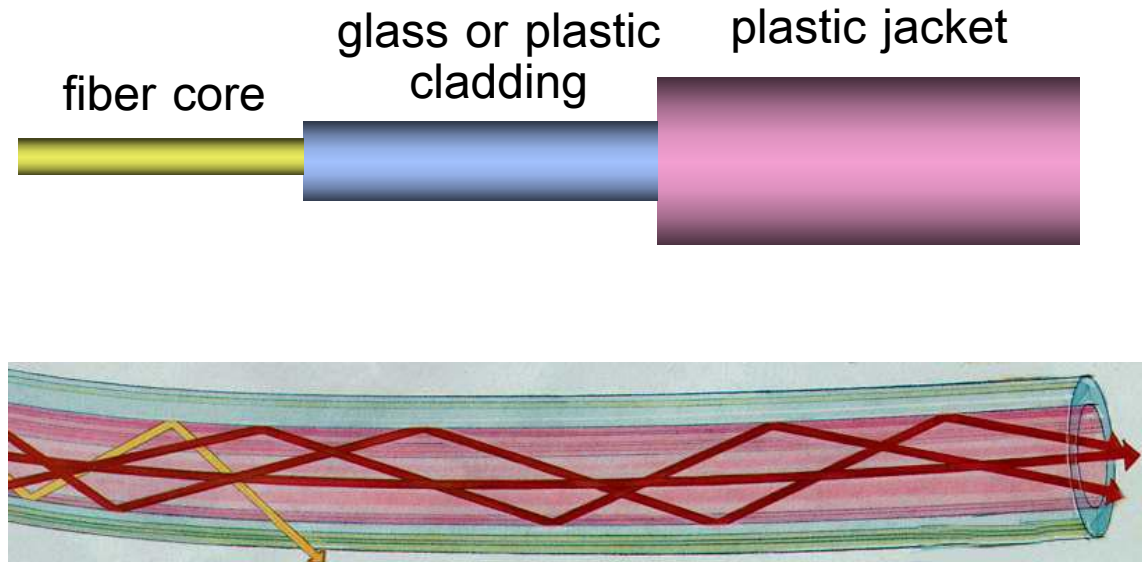

FIBER OPTIC CABLES

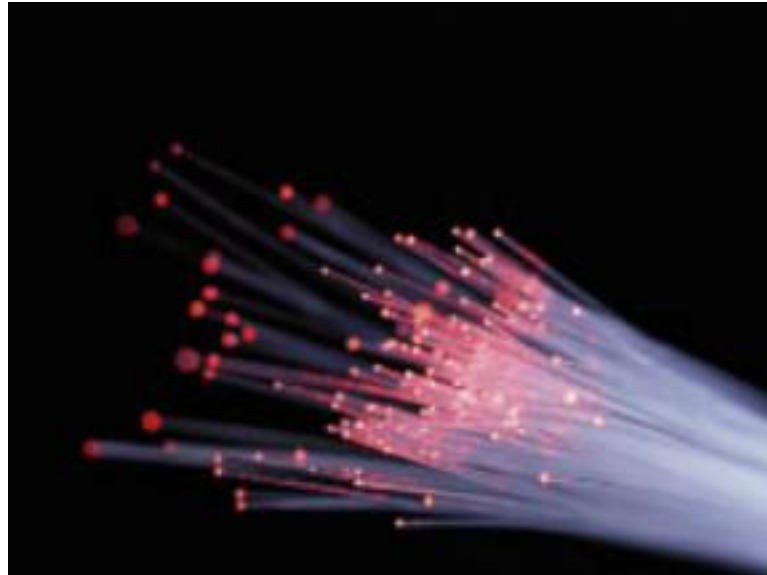
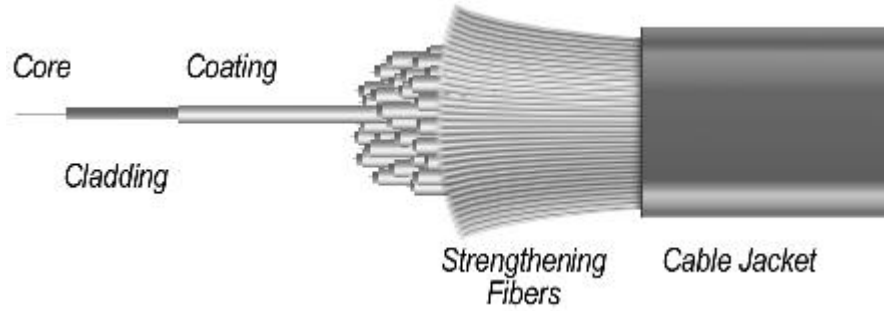

SOURCE: [SURFNET.NL](https://www.surfnet.nl)

DENSE WAVE-DIVISION MULTIPLEXING (DWDM)

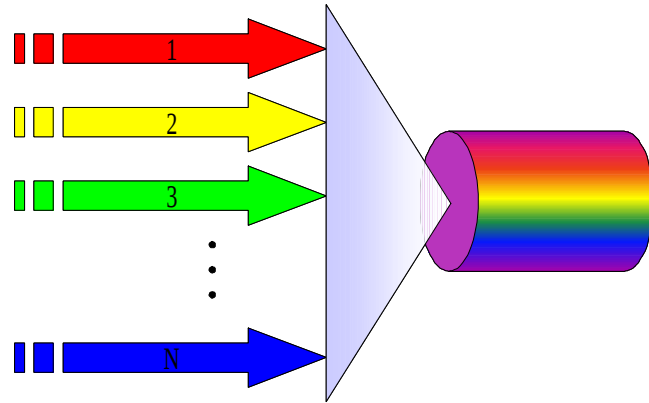

Multiple colors (frequencies) sent through the fiber at the same time, more than 100

Each color carries a separate signal

Allows huge bandwidth

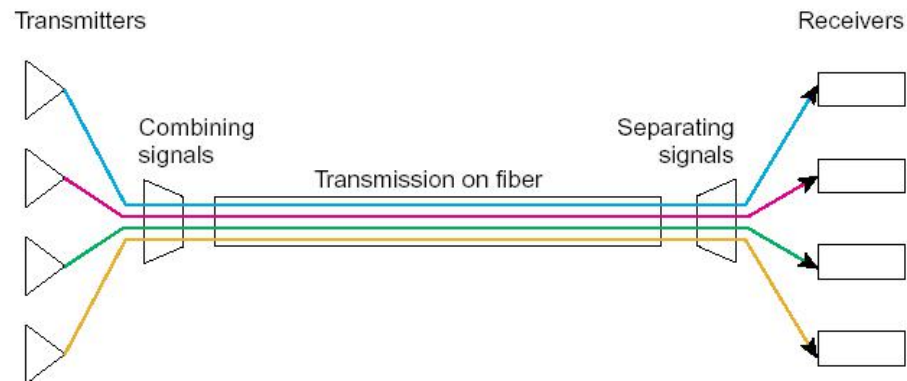

OPTICAL FIBER CAPACITY GROWTH 1983-2002

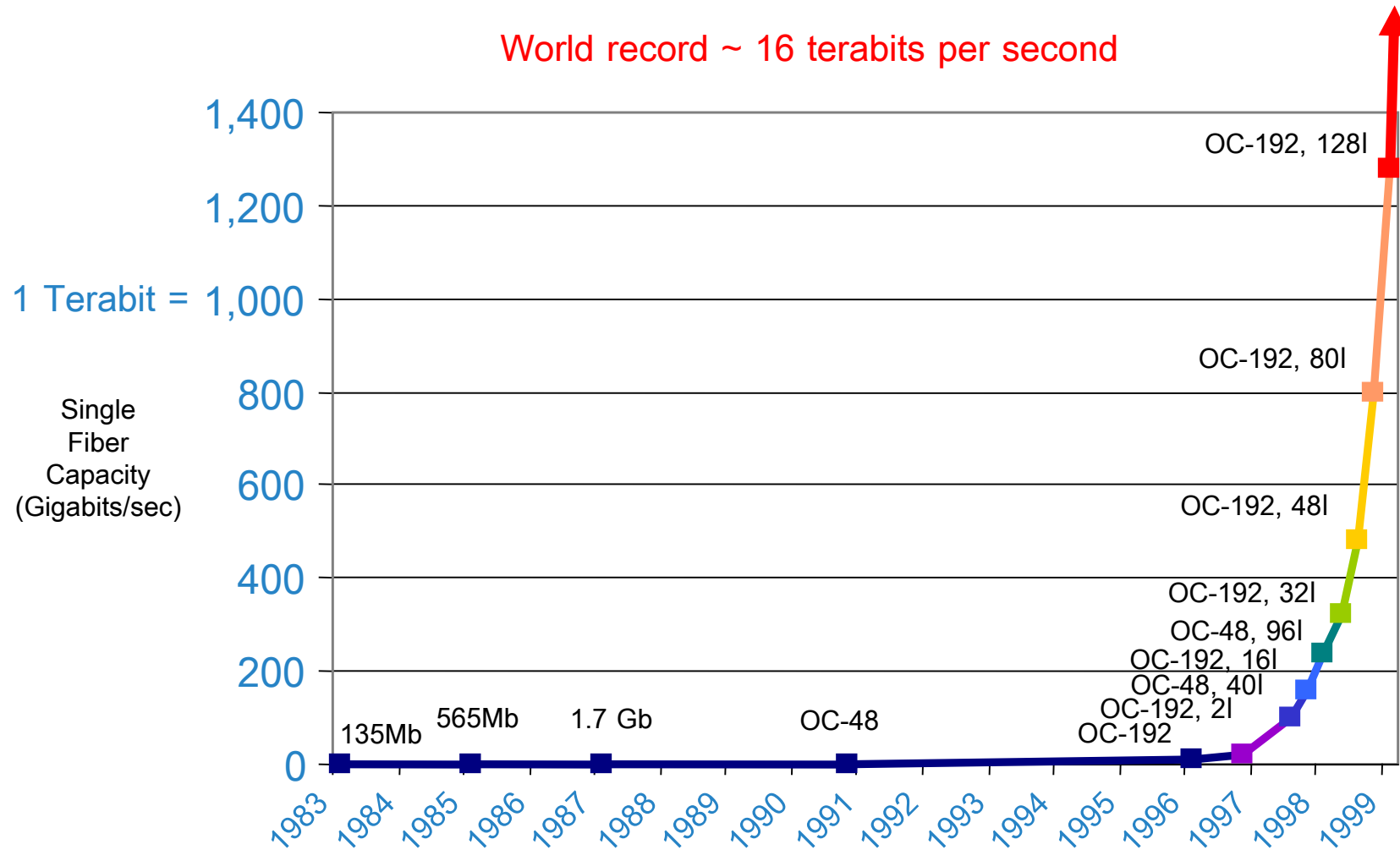

FIBER OPTIC LINES IN CENTRAL PHILADELPHIA

SOURCE: CYBERGEOGRAPHY.ORG



 TELECOM HOTEL

SUBMARINE CABLES IN NORTH EAST ASIA

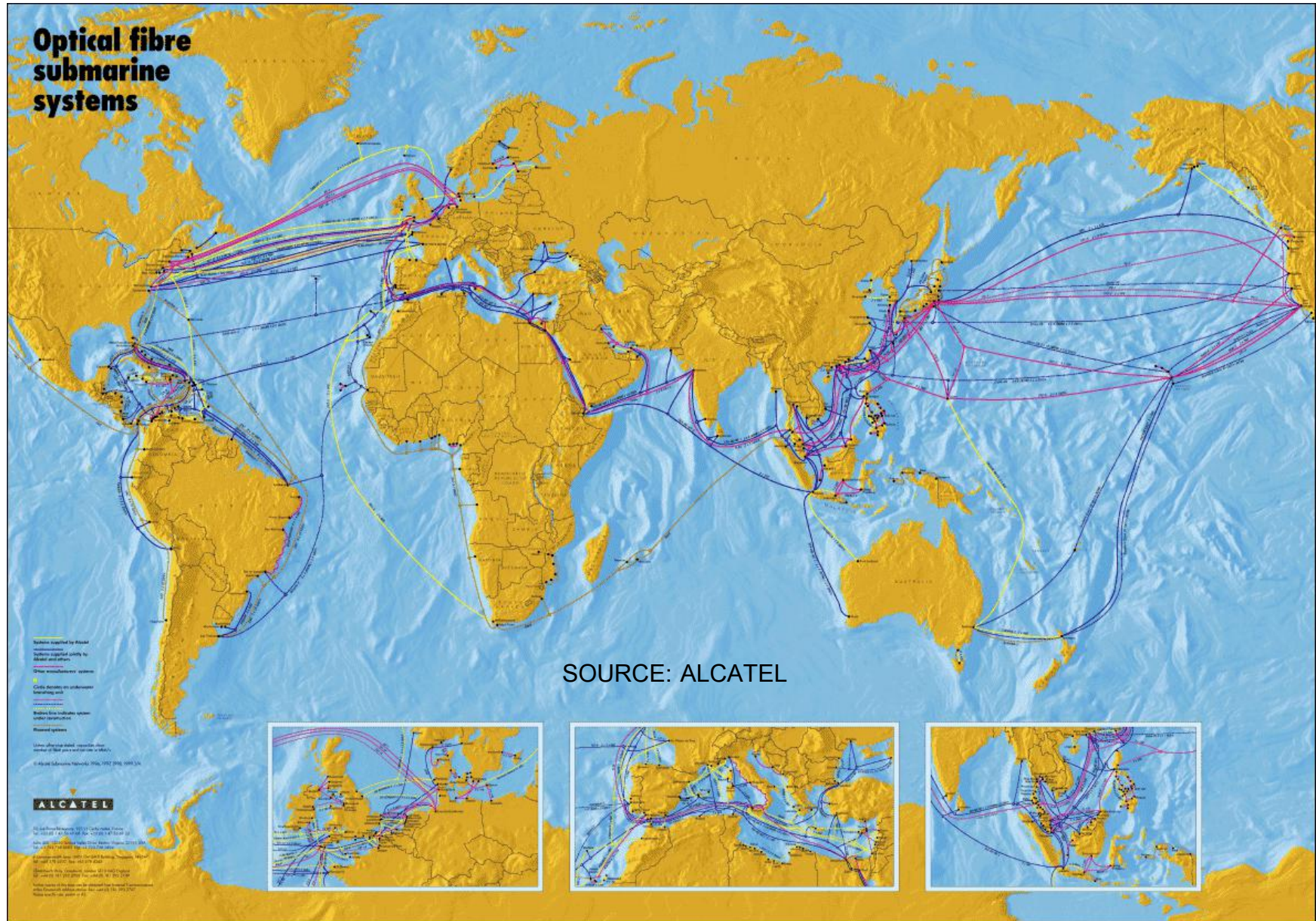

SUBMARINE CABLES: SOUTH EAST ASIA-MIDDLE EAST-WESTERN EUROPE 3 (SEA-ME-WE 3)

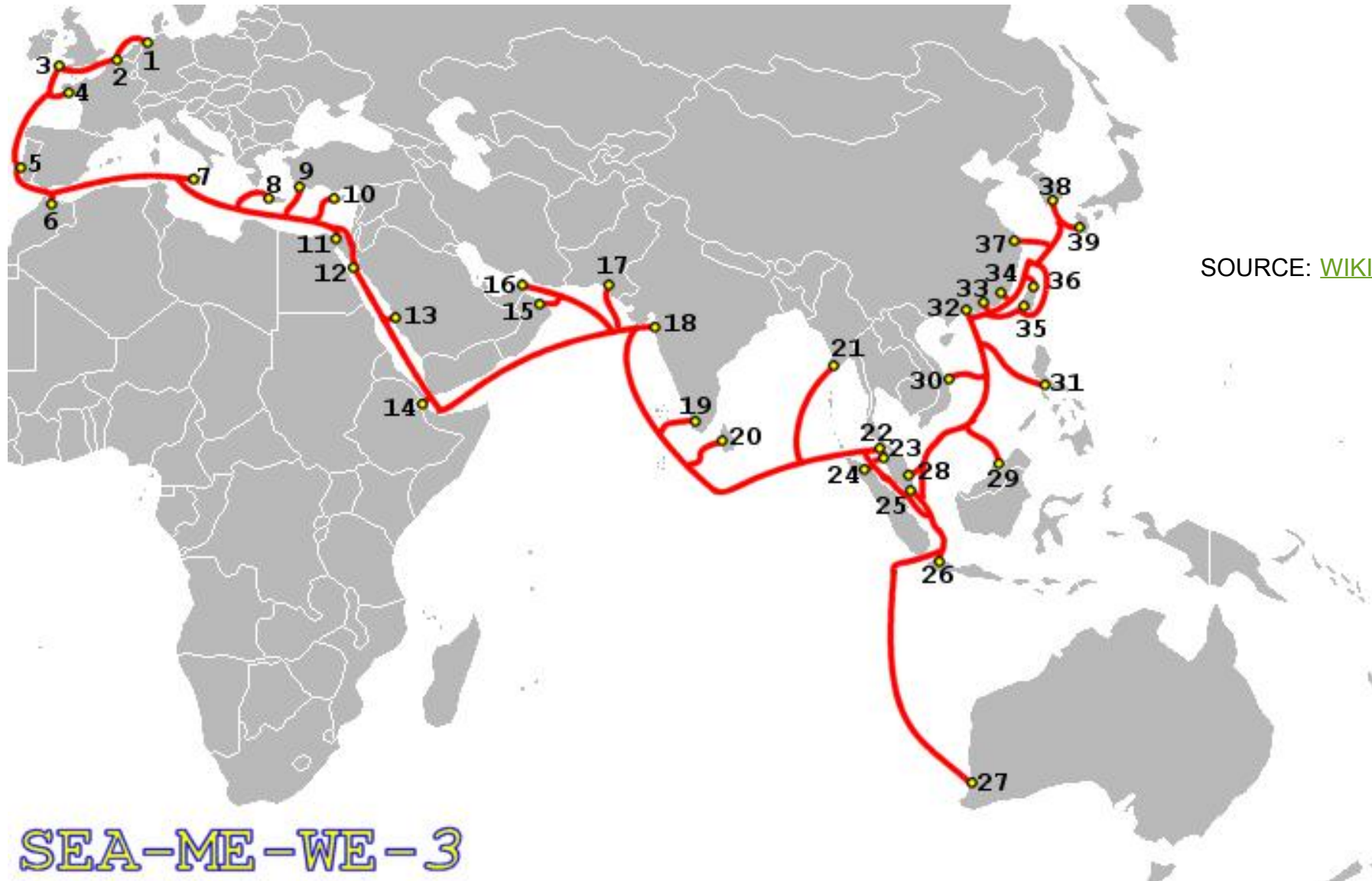

SOURCE: [WIKIPEDIA](#)

SEA-ME-WE-3

SUBMARINE CABLES:
SOUTH EAST ASIA-MIDDLE EAST-WESTERN EUROPE 4 (SEA-ME-WE 4)

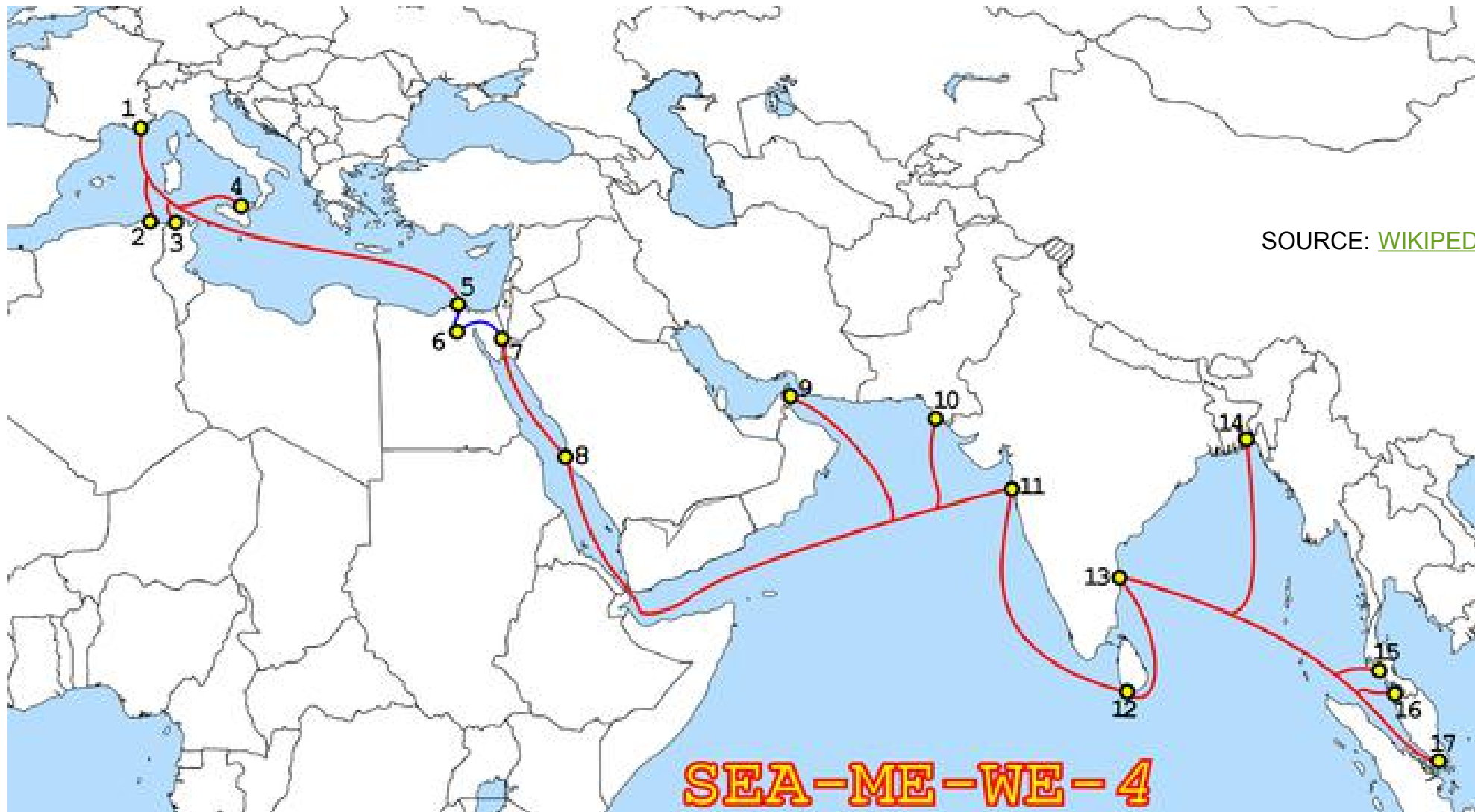

SOURCE: [WIKIPEDIA](#)

SUBMARINE CABLES IN NORTH EAST ASIA

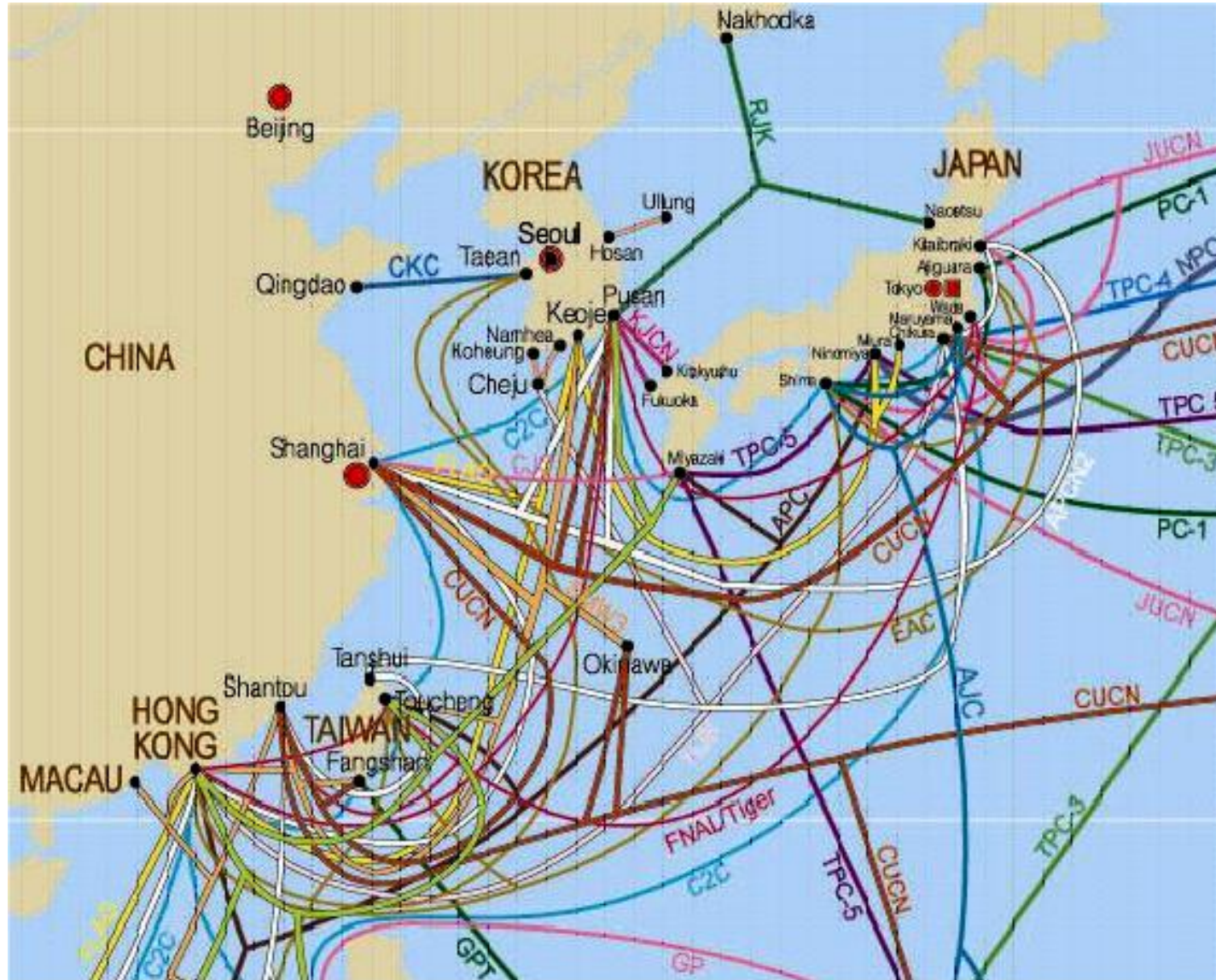

AFRICA-ONE SUBMARINE NETWORK

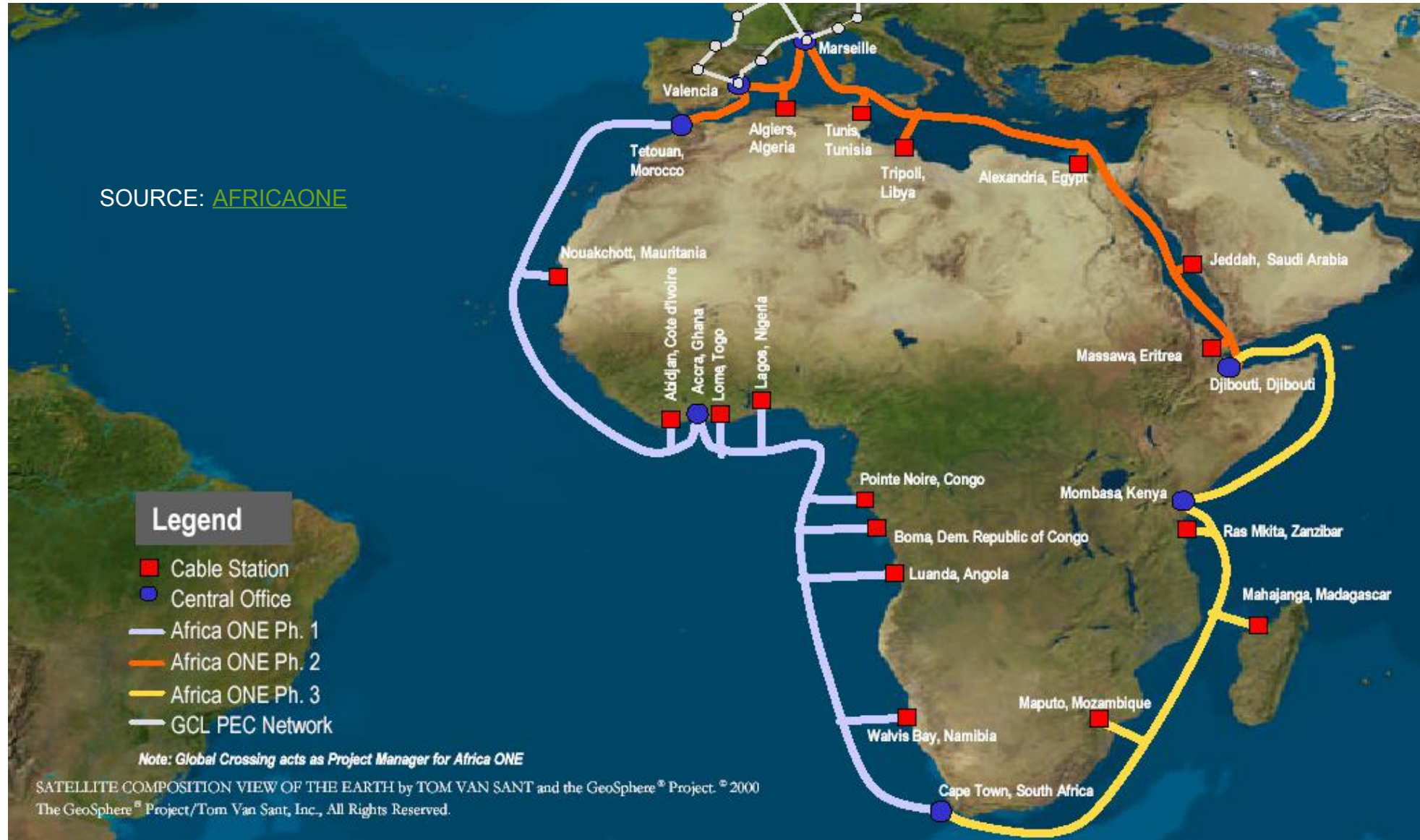

Telstar 10 Satellite Coverage

Telstar 10
C-band EIRP
76.5° E.L.

dbW = DECIBELS
RELATIVE TO
ONE WATT

EIRP =
EFFECTIVE RADIATED
POWER. = EAST
LONGITUDE

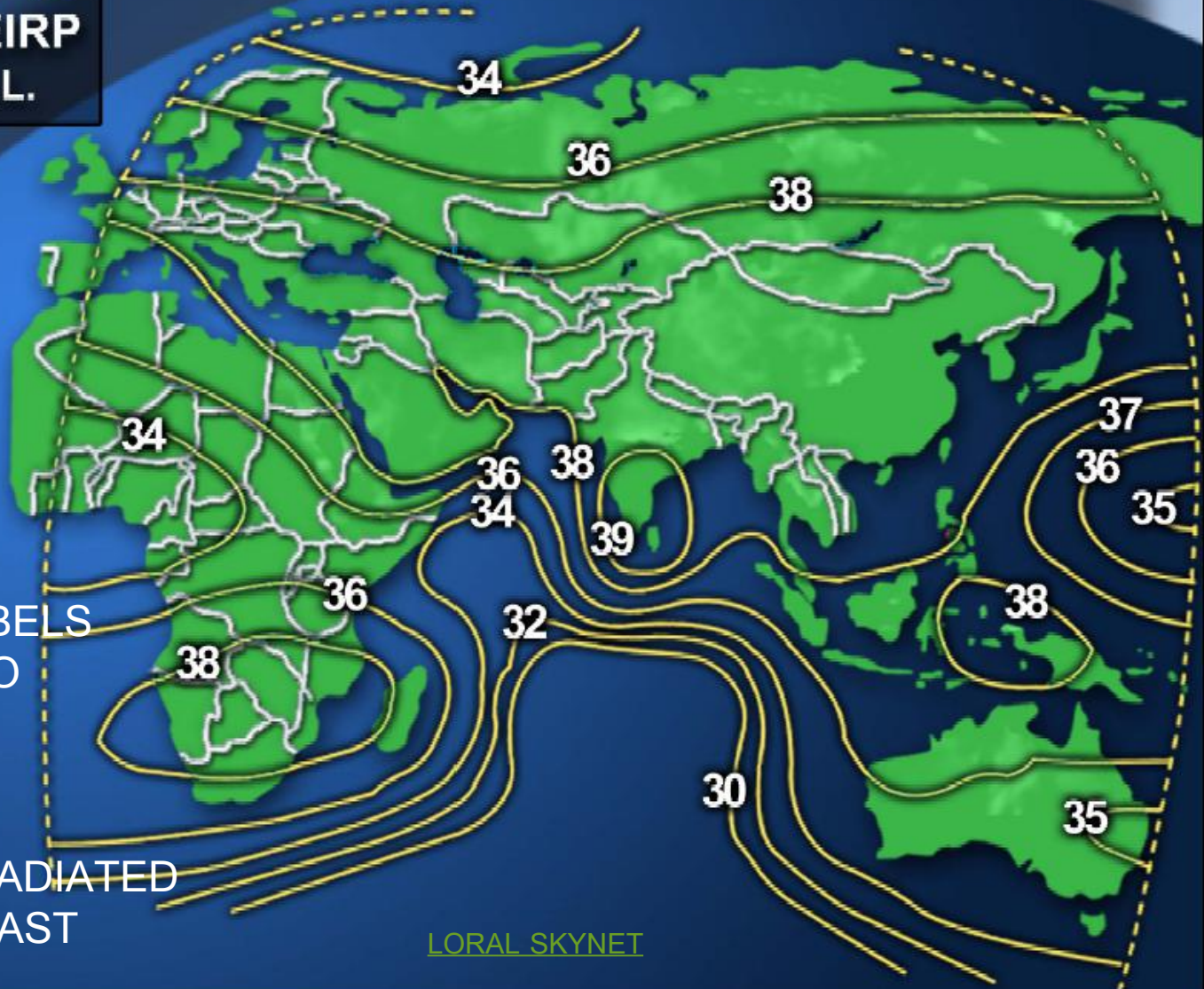

BIZARNET SATELLITE COVERAGE

Source:
Bizarnet.ro

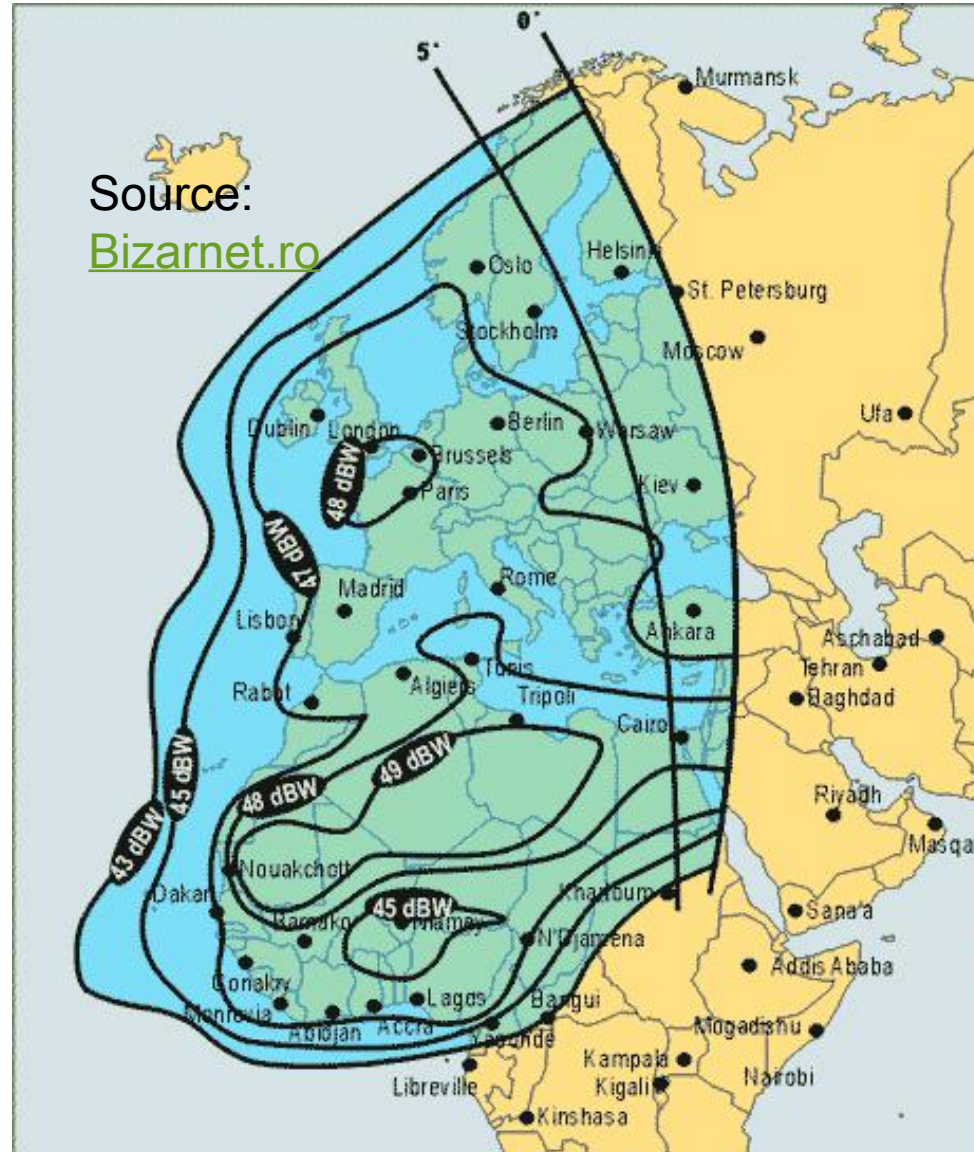

PAKISTAN EDUCATIONAL RESEARCH NETWORK (PERN) - SPONSORS

- ü Higher Education Commission
- ü Ministry of IT & Telecomm
- ü Pakistan Telecommunication Ltd (PTCL)
- ü National Telecommunication Corporation (NTC)

Source:

**Engr. Javed Ali
Memon**

Liaison Officer (PERN)
Higher Education Commission (HEC)
Islamabad-Pakistan
Email: Jmemon@hec.gov.pk

PERN CORE NETWORK

- Ø Using the Existing Optical Fiber System of PTCL/NTC and IP/ATM backbone of NTC
- Ø The network design of PERN consists of three nodal points (PoPs) at Islamabad, Lahore and Karachi
- Ø The interconnectivity between Nodal Points is 50 Mbps.
- Ø The educational institutions are connected to their respective nodal point by minimum 2Mbps link from the nearest exchange of NTC/PTCL using OFS, DXX , DRS, Radio or VSAT
- Ø The 155 Mbps Internet Bandwidth is distributed at three nodal points.

PERN Architecture

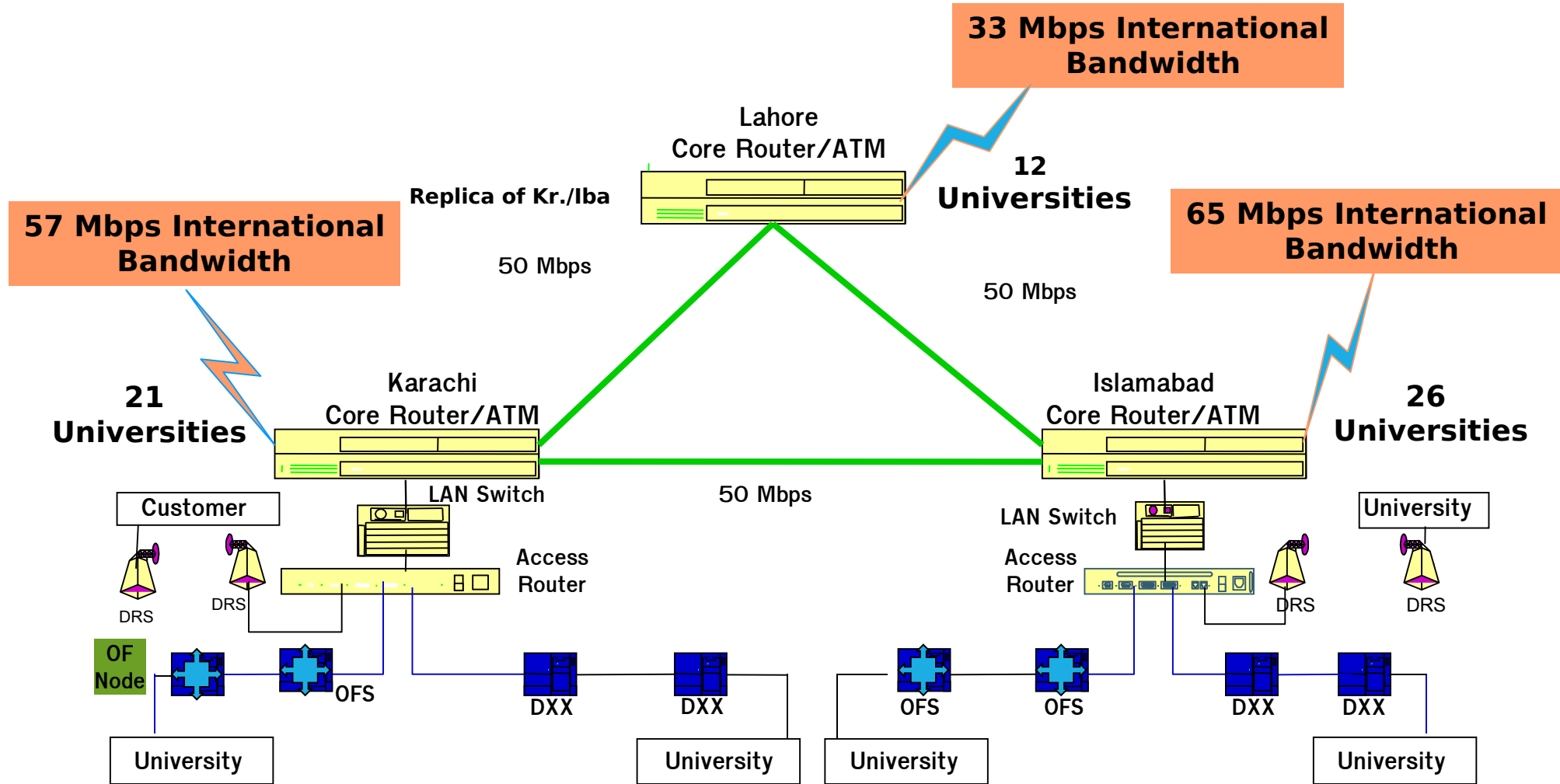

UPGRADATION IN PERN CONNECTIVITY FOR SINDH & BALOCHISTAN

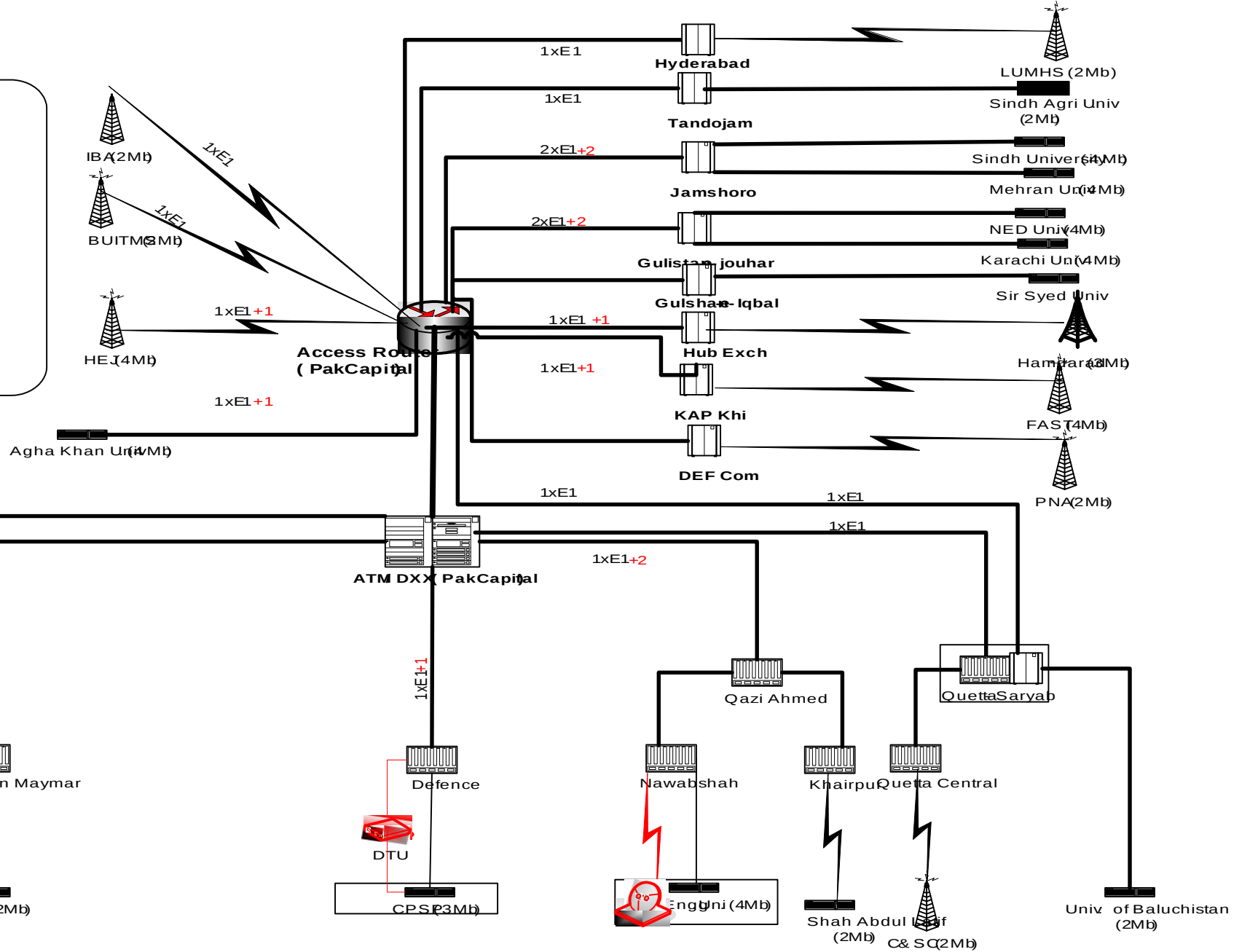
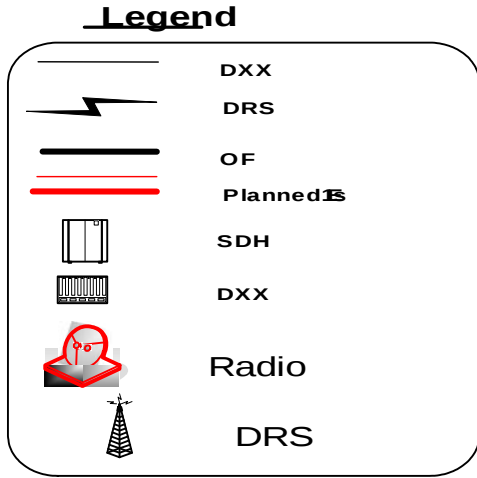

UPGRADATION IN PERN CONNECTIVITY FOR LAHORE & PUNJAB

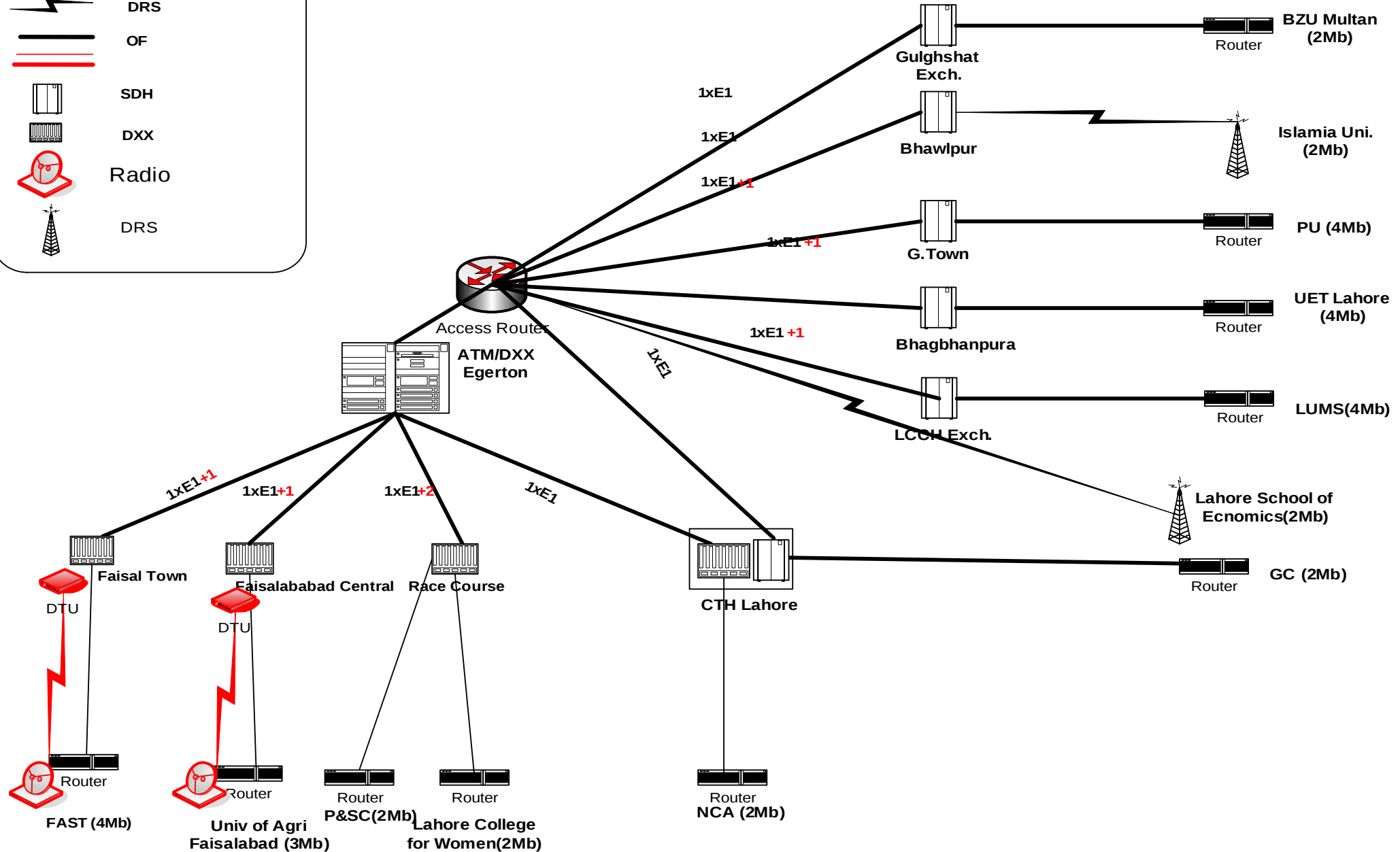
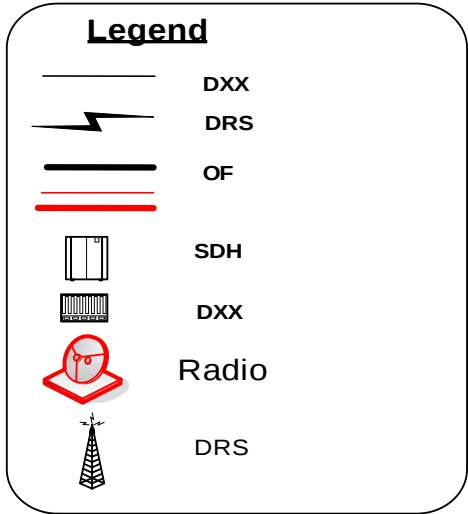

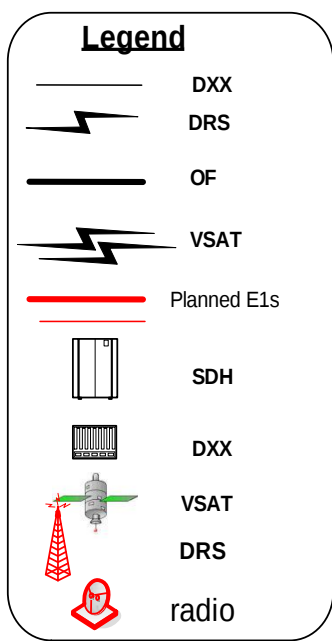

UPGRADATION IN PERN CONNECTIVITY FOR ISLAMABAD, AJK & NWFP

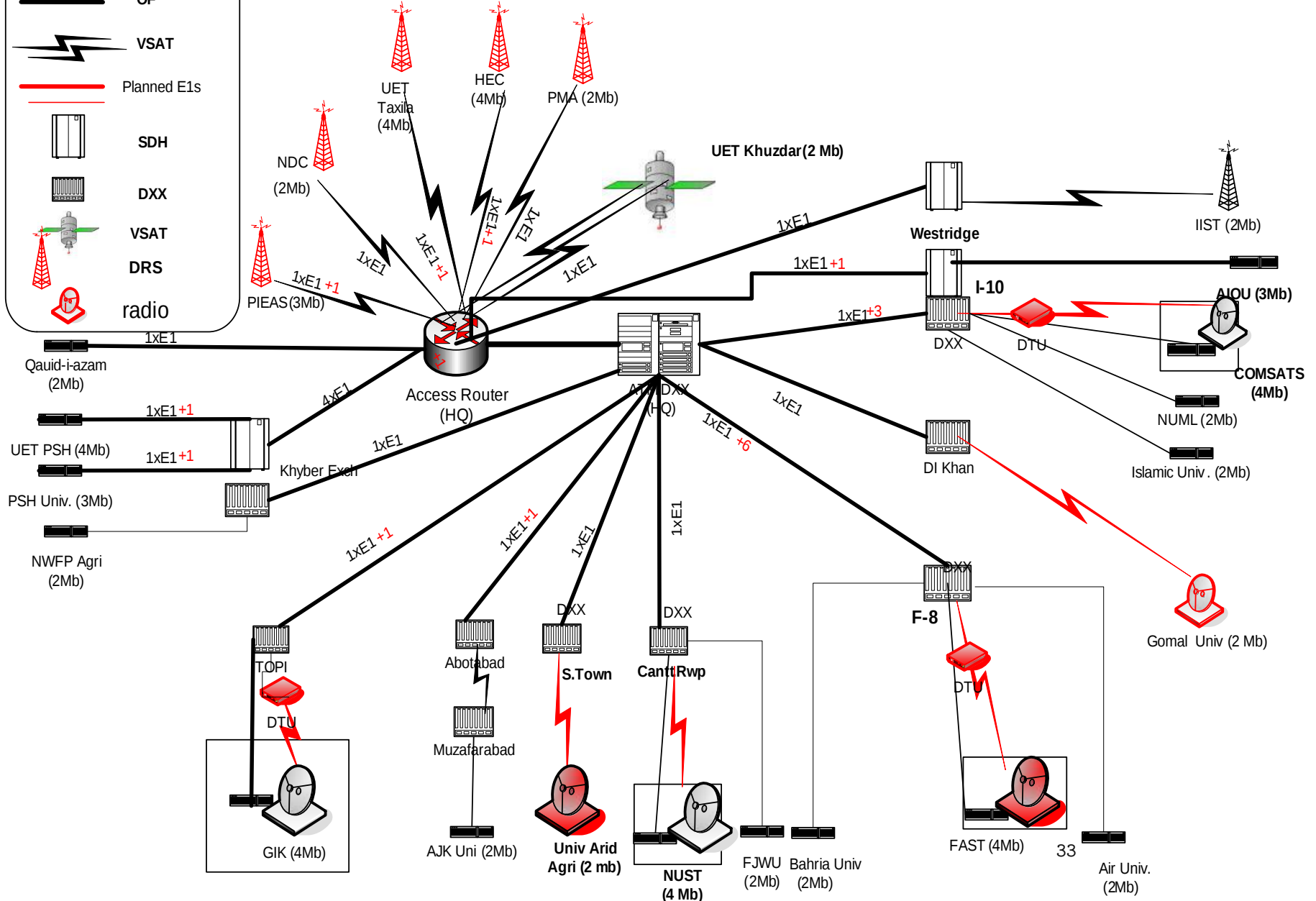

**CONNECTION SUMMARY
(PERN PROJECT)**

OFS	
Allma Iqbal Open University Quaid-e-Azam University Peshawar University University of Engineering & Technology	
Total	4
DXX	
Air University Bahria University, Islamabad College of Aeronautical Engineering COMSATS Institute of Information Technology COMSATS Institute of Information Technology, Wah Cantt: Fatima Jinnah Women University Ghulam Ishaq Khan Institute of ES & Tech International Islamic University National University of Computer & Emerging Sciences (FAST) National University of Modern Languages National University of Science & Technology NWFP University of Agriculture	
Total	12
DRS/VSAT	
Gomal University Higher Education Commission International Institute of Space Technology National Defense College Pakistan Institute of Engineering & Applied Sciences Pakistan Military Academy University of Arid Agriculture University of Azad Jammu Kashmir University of Engineering & Technology University of Engineering & Technology	
Total	10
Grand Total	26

OFS	
Bahauddin Zakariya University Government College University Lahore University of Management Sciences University of the Punjab University of Engineering Technology	
Total	5
DXX	
Lahore College for Women University National College of Arts National University of Computer & Emerging Science (FAST) Pakistan Administrative staff College University of Agriculture	
Total	5
DRS	
Islamia University Lahore School of Economics	
Total	2
Grand Total	12

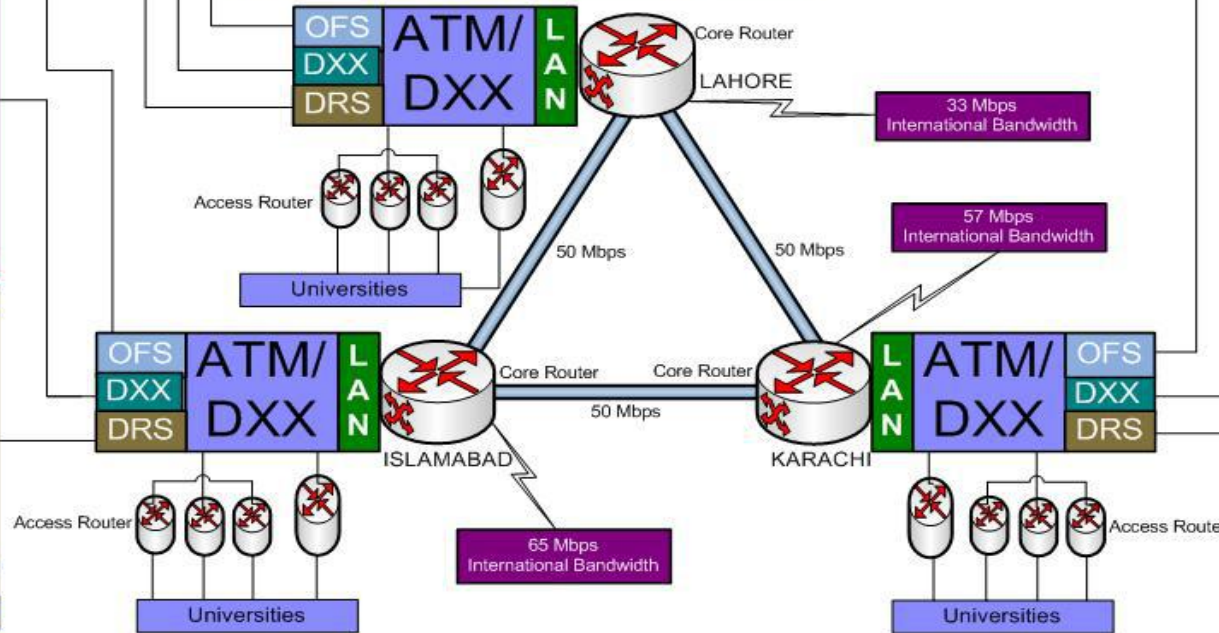

OFS	
Agha Khan University, Karachi Liaquat University of Health & Medical Sciences Mehran University of Engineering Technology NED University of Engineering Technology Sindh Agriculture University University of Balochistan University of Karachi University of Sindh	
Total	8
DXX	
College of Physicians & Surgeons Pakistan Karachi Institute of Information Technology Quaid-e-Azam University of Engineering & Technology Sir Syed University of Engineering Technology SZABIST	
Total	5
DRS	
BUITMS Command Staff College Hamdard University HEJ Institute of Chemistry Institute of Business Administration National University of Computer & Emerging Science (FAST) Pak Naval Academy Shah Abdul Latif University	
Total	8
Grand Total	21

BATCH	OFS	DXX	DRS	VSAT	GRAND TOTAL
TOTAL	17	22	19	01	59
INSTALLED	17	22	19	01	59
ONLINE	17	22	19	01	59

Pakistan Education and Research Network (PERN) & (PERN2)

Pakistan Education and Research Network (PERN) is a part of the overall vision and amongst the objectives of IT Action Plan . The project was financed by the Government of Pakistan in cooperation with PTCL (Pakistan Telecommunication Company Limited) Research and Development funds. The network was designed, operated, and maintained by NTC earlier and now by PTCL and it is managed by Higher Education Commission.

The Higher Education Commission Pakistan now aims to redesign Pakistan Education & Research Network (PERN) and establish a high speed dedicated National Research & Education Network (NREN) as PERN2 for the universities and other academic sectors of Pakistan. This will provide students, faculty members and researchers a fully integrated and dedicated communication infrastructure using advanced Information & Communication Technologies.

The purpose of National Research & Education Network (NREN) to achieve true collaborative research, knowledge & resource sharing and distance learning.

PERN2 will interlink all public/private sectors academic and research institutes of the country over an IP based infrastructure through metro fiber ring (Gigabit Ethernet) in the cities where facilities are available.

PERN 2 Equipment Location (HUAWEI Quidway NetEngine 20E-8)



IP ADDRESSES

Machines on the Internet need an addressing scheme (or couldn't receive packets!)

Each machine has a 32-bit address assigned by the [Internet Corporation for Assigned Names and Numbers](#) (ICANN).

In the U.S., [American Registry for Internet Numbers](#) (ARIN)

In Europe, [Réseaux IP Européens](#) (RIPE)

Addresses are written in dotted decimal notation:

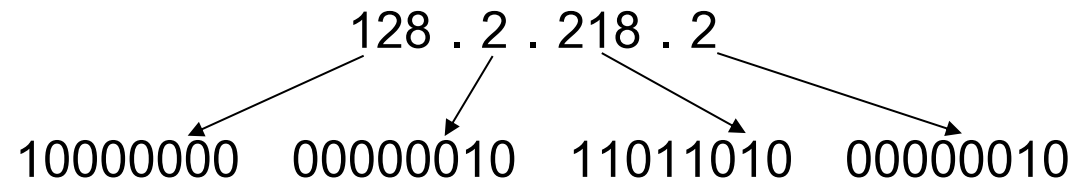

Current max number of IP addresses = $2^{32} = \sim 4,000,000,000$

IPV6

Increases # of IP addresses from $2^{32} \approx 4$ billion to $2^{128} \approx 10^{39}$

Designed for faster routing

Supports Quality of Service (QoS), packet priorities

Allows multiple streams to the same IP address, e.g. audio, video, HTML

DOMAIN NAMES

IP addresses are inconvenient to remember
128.2.218.2 v. **euro.ecom.cmu.edu** (fully qualified)

Domain names are alphanumeric aliases for IP addresses. They form a tree structure of FQDNs:

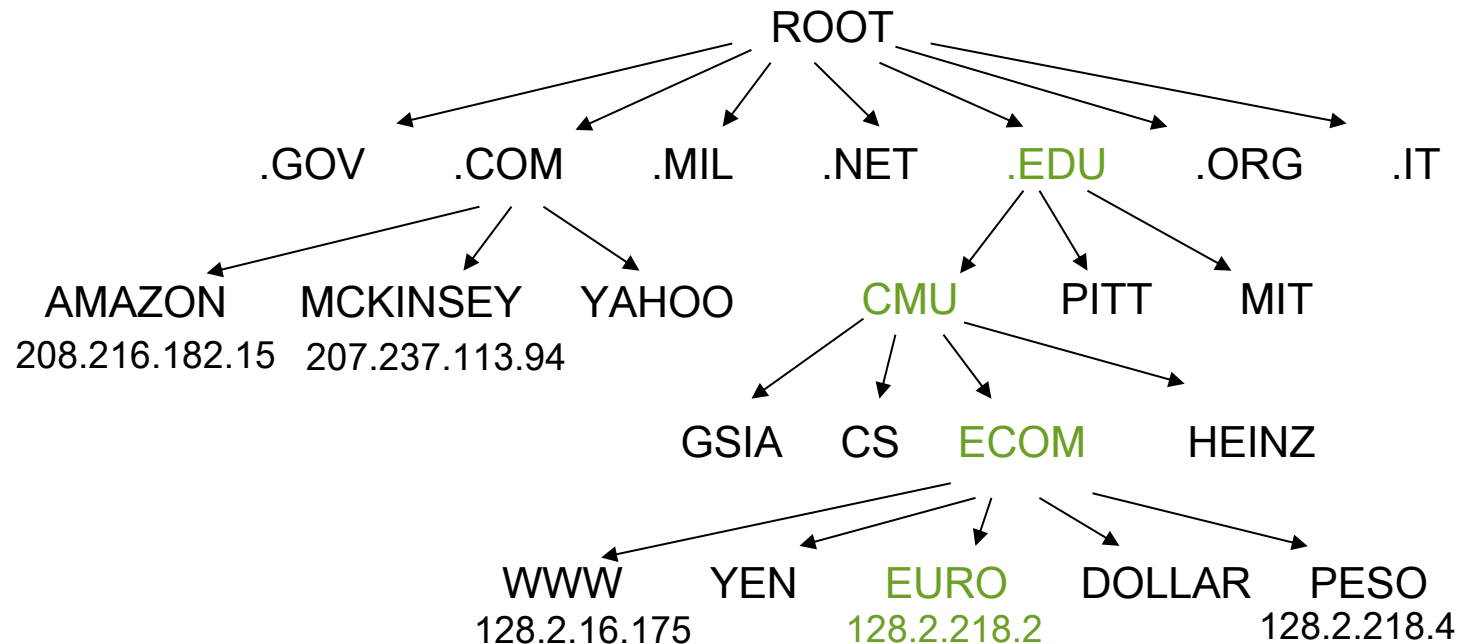

URL: UNIFORM RESOURCE LOCATOR

URL identifies a specific resource on a server in a domain

URL tells what protocol to use to access the resource

URL format:

<http://euro.ecom.cmu.edu/program/courses/index.shtml>

`protocol://domain_name/path_name`

URL: TWO HIERARCHIES SPLICED

euro.ecom.cmu.edu/program/courses/tcr751

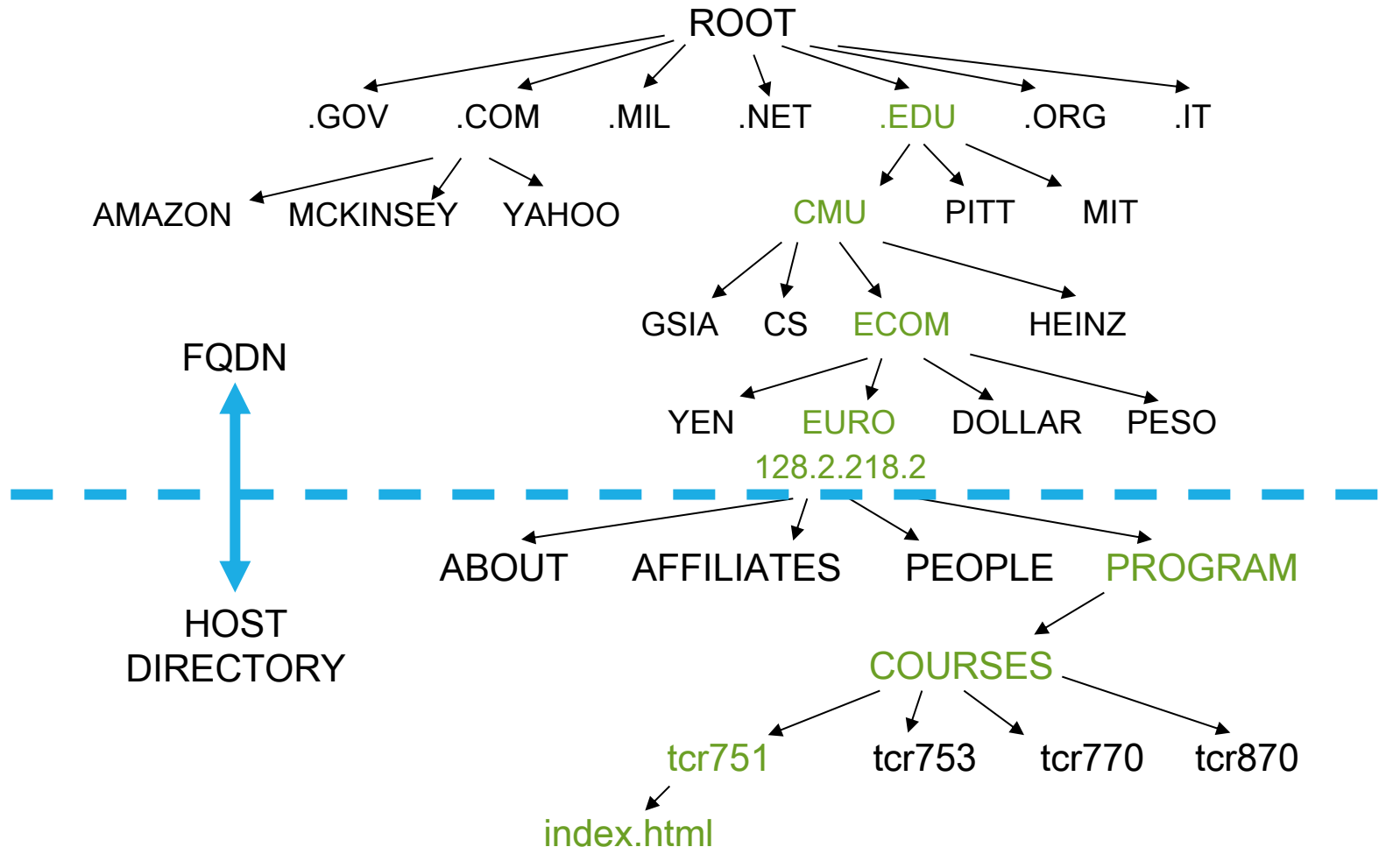

Q&A

ASSIGNMENT #1

Q1. Find 3 NGIX and STAR TAP in this diagram on slide 13 ?

Q2. What is BT, MCI, TIS, STIX and TG in slide 14?

Q3. What are the current upstream providers of PERN2 these days?

Pls. send your assignment by email before next class to adeel.akram@uettaxila.edu.pk with subject: MCIT Assignment #1 – Registration Number